

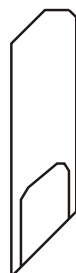

QF MANUAL

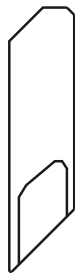

Page	2	<u>GENERAL INFORMATION</u>
	2	<u>INTRODUCTION</u>
	3	<u>POSITION OF THE SYSTEM IN THE SHOP</u>
	4	<u>DISTURBANCES</u>
	5	<u>ACTIVE/PASSIVE NOISE SOURCES</u>
	6	<u>TOOLS FOR FIELD SERVICE</u>
	7	<u>INSTALLING A SINGLE SYSTEM (2000 system)</u>
	8	<u>INSTALLING A DUAL SYSTEM (3000 system)</u>
	9	<u>MASTER/SLAVE (SYNCHRONIZING 2 TRANSMITTERS / 4000 system)</u>
	11	<u>HOW TO SYNCHRONIZE TWO TRANSMITTERS</u>
	12	<u>MORE ABOUT SYNCHRONISATION.</u>
	13	<u>SLAVING MORE THAN TWO TRANSMITTERS</u>
	14	<u>TYPICAL PITFALLS IN SLAVED SYSTEM</u>
	15	<u>ALIGNMENT OF SYSTEMS "FROM SCRATCH"</u>
	16	<u>ADJUSTMENT IN THE RIGHT ORDER</u>
	18	<u>DETECTION ACCURACY</u>
	18	<u>BEEPER TIME</u>
		<u>DRAWINGS</u>

GENERAL INFORMATION

Telsec's QF system is an advanced anti-shoplifting system which may be installed without special skills and/or much technical knowledge.

Combining digital and analog technologies and the use of "dedicated" chips enabled us to construct this unique system.

This system has an extremely high degree of immunity against false alarming and will usually work quite happily under circumstances where competitor's systems will no longer give satisfactory results.

As the system is of a modular construction, servicing is -whenever necessary- extremely easy (simply replace a defective module) while upgrades can simply "plugged in" as they come available.

As the whole design has been done with flexibility in mind it will not come as a surprise that any system -once installed- can, at a later date always be expanded (more antennas) or upgraded to the latest technology.

INTRODUCTION

In order to make certain that optimum results are obtained all times, a minimal knowledge about the use of the QF system is required.

As normally all systems come completely pre-aligned, it will not be necessary to make lots of complicated adjustments.

The only adjustment would be the sensitivity of the system (if no Automatic Gain Control is installed), to be able to make this adjustment only a small screwdriver is needed.

If a system does not perform well, always carefully check if the rules for installation have been followed, rectify if necessary.

A poorly installed system will never perform well. Changing preset adjustments will make the situation worse.

POSITION OF THE SYSTEM IN THE SHOP

The success of any installation depends entirely upon the way a system is installed in the shop. Reading the following pages will clarify why.

The system basically consists of a (very sensitive) receiver and a low power transmitter.

The transmitter activates the labels and their (weak) signals are received by the receiver and recognized as being valid alarm signals.

As the label signals are rather weak and lots of disturbing signals are received at the same time, the receiver has been given the ability to discriminate between "random noise" and label signals.

Picture yourself in a room filled with shouting people. A person standing at the other side of the room tries to tell you something but this message gets lost in the noise.

This is the sort of situation that is created if a system is not properly installed. The noise, in this case being electrical noise, from some device and the speaker at the other side of the room is the label which signal "drowns" in the noise.

Although the receiver's sensitivity is very high, the factor that limits the usable distance between the antennas is always the ambient noise. The higher the ambient noise, the harder it becomes to detect a label at a given distance.

By carefully studying the lay out of the shop BEFORE the installation and carefully planning the position of the system avoiding circumstances/objects that introduce unnecessary noise in the system, we can make certain that the system will perform well and never "misses" a shoplifter.

Once we have made ourselves familiar with the causes of ambient noise it is easy to avoid these and make a success of the installation from the very beginning.

If we do not observe these simple rules and simply bolt the system down we will find that having to change the position of the antenna at a later stage leaves a set of holes in the customer's shop floor, something which is not often appreciated.

DISTURBANCES

Sources of noise:

In a shop-situation we may encounter that a number of things have a certain (negative) influence on the way a system can perform.

All of these have in common that they introduce noise in the system which will make label-detection difficult and in some cases even impossible.

The common noise sources are:

- A > VERTICAL mains lines within 2 meter distance from the system.
- B > Neon displays near the system.
- C > F.L. tubes right above the system.

These devices may be considered ACTIVE NOISE SOURCES as they emit noise themselves. The effects that these may have on the system are:

- less sensitivity
- poor detection
- slow detection

Besides these active noise sources there is a second group of noise-introducing items, these do not emit noise themselves but may induce already present noise into the system by acting as large "antennas".

The most common PASSIVE NOISE SOURCES are:

- A > Doors having a fully closed metal frame
- B > Large metal objects (f.e. mobile displays)
- C > Metal frames (f.e. metal frame around a door-mat).

These items may, when they are within 0.5 meter distance from an antenna, work as big "loop antennas" and disturb the system's antenna-balance causing severe interference and poor detection.

ACTIVE/PASSIVE NOISE SOURCES

Active Noise Sources:

- 1 > Keep VERTICAL mains lines away from the antennas.

If a mains line runs vertically along the wall at 2 meter distance almost all noise has disappeared. If the worst comes to the worst it may be necessary to reroute a mains cable. As HORIZONTAL mains cables hardly introduce any noise in the system it is always possible to reroute a cable horizontally and come back to the original mains' outlet if necessary.

- 2 > Should we find that a neon display or F.L. tubes near the system produce excessive noise, these noise sources should be removed or replaced.

Passive Noise Sources:

- 1 > Metal framed doors should never be allowed to turn between the system's antennas, this upsets antenna-balance, results in poor detection and may even cause false alarms. At all times keep a 0.5 meter minimum distance between metal framed doors and antennas.
- 2 > Instruct your customer not to place any (mobile) displays (which may contain labeled merchandise) within 1 meter distance from the system.

Always try to keep a "safety area" of appr. 1 meter around the system in which no goods are displayed. Most so called "false alarms" are caused by labeled merchandise which is relatively close to the system.

TOOLS FOR FIELD SERVICE

To enable you to install a system some tools are necessary.

A > Tools for mechanical work.

B > Tools to set up the electronics.

Tools from category A could be:

- hammer drill
- disc cutter
- handtools

Tools from category B could be:

- small screwdriver
- universal meter
- System checker (TLT 75)
- (portable) oscilloscope
- 10:1 probe

INSTALLING A SINGLE SYSTEM (2000 system)

After we have convinced ourselves that the system's position is not in violation of any of the rules we proceed to test the system.

Of course, we could start drilling holes in the floor and bolting the system, however if it should turn out that we have overlooked a certain complication which makes it necessary to change the system's position afterwards, we have caused unnecessary damage to the shop's floor.

To avoid this we proceed by wiring the system and positioning the antennas and PSU at the planned positions **WITHOUT BOLTING ANYTHING OR WITHOUT DRILLING HOLES IN THE FLOOR.** (Make the connections in conformity with **DR 2-1**)

After we turn the key on the PSU the system should work. All we have to do now is wait for the automatic gain to adjust itself. (Or set manual gain if this option is chosen.)

Manual gain is only required in case of certain kind of noise which influence makes the automatic gain of the receiver going down.

To adjust the gain manually:

- a > Put the jumper of GAIN MAN/AUTO on position GAIN MAN.
- b > Locate the position of the pot.mtr. marke "GAIN" on the receiver board.
- c > Locate the position of the LED marked "Label" on the receiver board.
- c > Keep any label well away from the system, slowly turn the "GAIN" pot.mtr. clockwise up to the point were the LED on RM3 marked "label" just starts to blink faintly.
- d > Slowly turn the same pot.mtr. slowly counterclockwise until the blinking of the "label" LED has JUST stopped.

Now the system should perform well, it should pick up almost 100% of all labels that pass between the antennas.

After we are sure that the system performs well at the proposed spot we can continue by drilling the holes in the floor etc.

Using a disc cutter we can cut a groove in the floor in which we hide the cable that connects the two antennas to the PSU.

After the cable has been laid in the groove, it is covered with fast setting cement, the result looks very professional.

INSTALLING A DUAL SYSTEM (3000 system)

When having read the information concerning installation of the very basic single systems, extending the installation to a DUAL system is relatively easy to do.

All we need to do is install an extra receiver next to the other side of the transmitter antenna (Make the connections in conformity with **DR 3-1**)

This set up looks like:

Receiver=Transmitter=Receiver

MASTER/SLAVE BASICS (SYNCHRONIZING 2 TRANSMITTERS / 4000 system)

The transmitter used in the QF system produces a FM modulated signal. The transmitter's signal "sweeps" across a certain band (f.e. 128 times per second.)

Should we try to build an installation like f.e.:

Receiver=Transmitter=Receiver=Transmitter

We can expect severe problems as the two transmitters do not transmit the same signal at all times (they will interfere with each other).

If we do not synchronize the two transmitters the system simply will not work.

The same problem may be encountered if we install two independent systems in one shop (two separate entrances). Here too we will have to synchronize or "slave" the two systems to prevent interferences.

To understand how this works, we shall have a closer look at the transmitter board.

On the transmitter board we find two modules marked TST HF/LF OSCILLATOR (TM1) and TST HF POWER/CONTROL (TM2). See **DR1.1**

Module TST HF/LF OSCILLATOR contains a LF oscillator and a VCO circuit. It produces a weak rf signal which is (frequency) modulated by a f.e. 128 Hz signal.

Module TST HF POWER/CONTROL amplifies the signal from TST HF/LF OSCILLATOR to a level strong enough to make the system work.

Looking at the transmitterboard we spot 4 test points.

The one marked "GND" can be used to ground the probes shield, the one marked TP3 can be used to check the LF sine wave signal from TST HF/LF OSCILLATOR. Test points TP1 and TP2 can be used for checking the transmitted signal.

Above module TST HF/LF OSCILLATOR we find 3 pot.mtrs. One is marked "SWEEP", this one can be used to change the system's bandwidth (factory adjusted), the one marked "FREQ." is used to adjust the center-frequency of the system (factory adjusted), the one marked GAIN enable us to change the output level of the transmitter.

On the bottom side of module TST HF/LF OSCILLATOR we see a jumper (labeled 3/5/8). Do not change this its position. This jumper is used to change the entire system to another band. How to do this, will be described in the following chapters.

On top of the board we find a rotary switch which is adjusted to resonate the antenna. This one should not be touched normally.

Now, having seen how the transmitter is constructed and understanding what is what, we will try to explain how we can synchronize two transmitters.

HOW TO SYNCHRONIZE TWO TRANSMITTERS (DR4.3)

To be able to "synchronize" two transmitters we need to connect the two units with a co-axial cable. We prefer to use a rather thin co-axial cable which is commonly known as a type RG-174-U (this is an international standard-type name).

This particular type of cable has an impedance of 50 ohms and has an outside diameter of 3 mm.

One side of the cable is connected to the "master/slave" connections on one of the transmitters, the other side is also connected to the same connections at the second transmitter. These connections are clearly marked on the boards.

Next step is to remove module TST HF/LF OSCILLATOR of the SECOND transmitter thus converting it to a so-called "slave" unit.

The first transmitter -which still contains all modules- will be referred to as the "master" transmitter.

Connect the delay cable and put the LINK jumper on position OFF.

Looking at the transmitter's block-diagram it is easy enough to understand how this works.

What we have done is basically the following: The signal is coming from the master units' TST HFLF OSCILLATOR module and is coupled into the amplifiers TST HF POWER/CONTROL module of both transmitters.

As the two transmitters are of similar constructions and both are fed with the same signal, their output is bound to be synchronous.

The only thing we need to adjust is the output level of the transmitters, this is done by turning the gain pot.mtr.

Measuring the output level can easily be done using an oscilloscope using a 10:1 probe connected to TP1 and TP2. The value that we measure this way is of course a V_{pp} value. Adjust the output pot.mtr. ON BOTH transmitters so that both transmitters have an equal output.

This is all we have to do to synchronize the two transmitters and make the system work well.

MORE ABOUT SYNCHRONISATION.

If we draw the block diagram for the complete set of slaved transmitters we can easily understand that second (slave) transmitters receives its signal from the masters' TST HF/LF OSCILLATOR with a certain delay as the signal has to travel through the co-axial cable which connects the two transmitters. This causes a certain phase shift between the two transmitter signals.

The phase difference between the two transmitted signals causes some "confusion" in the receiver that stands exactly between the two transmitters and as a result the detection will not be quite as good.

Fortunately, to remedy this is very easy once you know how.

If we can find a way to delay the signal which comes from the TST HF/LF OSCILLATOR module and goes to the "masters" TST HF POWER/CONTROL module just as much as the delay caused by the length of co-axial cable which connects the masters' TST HF/LF OSCILLATOR with the slave's TST HF POWER.CONTROL, we can be certain that both transmitter signals are equal phase.

The obvious way to achieve this is to insert equal lengths of the same co-axial cable between TST HF/LF OSCILLATOR and **both** the TST HF POWER/CONTROL.

This way we can be absolutely certain that the drive-signal from TST HF/LF OSCILLATOR reaches both TST HF POWER/CONTROL at the same time.

After we have decided which length of co-axial cable is needed to connect the master and slave unit we cut a second piece of co-axial cable to exactly the same length. The master and slave unit are connected in the normal way.

Now the system is ready to be aligned as discussed previously. One slight problem remains as we cannot predict whether the two transmitters operate in the same phase or in opposition. To determine this, we need to do the following test:

After correct alignment of the system we test the systems sensitivity by holding a tag against our breast and approaching the system in the center between the two antennas. The system will probably give an alarm when we are f.e. 45 cm away from the antennas.

Next, cross the antennae-wires in ONE of the two transmitter units. Once more check the sensitivity in the same way without changing any of the adjustments.

The second time we find a bigger distance, the transmitters operate in the correct mode. Should we find a smaller distance the second time, this means that the first time was correct and we have to change the antenna wiring back to normal.

SLAVING MORE THAN TWO TRANSMITTERS

If more than two transmitters have to be synchronized, the use of a special so called CSU (Central Synchronizing Unit) becomes necessary.

This unit contains a special "driver transmitter" which supplies a signal identical to TST HF/LF OSCILLATOR's output to a large number of outputs. Every output on this unit has a 50 Ohms termination so all co-axial cables that connect the slave transmitters to this unit are properly terminated.

The CSU unit uses a normal PSU for its power supply needs. This PSU should preferably not be connected to any of the antennas.

Position of the CSU in an installation should be more or less "central" in order to minimize the necessary lengths of co-axial cables connecting the CSU with the transmitter units.

Having read and understood the preceding explanations it might be clear that, if f.e. a "4 antenna in line" system is to be synchronized the length of the two co-axial cables that connect the CSU with the two transmitters in this system should have equal lengths, if at the same time a second (f.e.) single system is synchronized with the same CSU and the single system is several meters away from the larger system, the length of the cable towards the single's transmitter is simply "as needed".

All adjustments in the CSU are factory aligned and should not be touched. The remaining adjustments are the normal receiver adjustments and the adjustments of (slave)transmitter outputs.

TYPICAL PITFALLS IN SLAVED SYSTEM

When comparing the performance of a slaved system with a non-slaved system you may find that the performance of the slaved unit is not quite up to the same standard.

The noise level of a slaved system could be considerably higher than normal which limits the max. usable sensitivity.

The reason for the increased noise level is the length of co-axial cable which connects the two (or more) systems as this may pick up noise from f.e. mains cables or neon lights.

To prevent noise from entering the system the following "trick" is used:

Take the co-axial cable where it connects to the TX board connector and wind the cable approximately 10 turns through a ferrite ring core PHILIPS no. 4322-020-97070.

This should be done at BOTH sides of the co-axial cable if the system consists of the normal transmitter and one "slave" transmitter.

If a CSU is used, the ferrite toroids are only used at the side of the slave transmitters.

This simple cure prevents noise collected by the cable from entering the system and spoiling its performance.

Extreme Noise In Slaved System

A mistake which is easily made and overlooked in slaved systems may lead to very poor performance of the systems.

As explained before VERTICAL cables always need to be at least 2 meters away from the systems' antennas to prevent excessive noise in the system's receiver.

If, however the co-axial cable which connects the transmitters runs vertically near any of the systems' antennas, you may find that the systems work very poorly indeed.

The "vertical cable rule" is ALSO TRUE FOR CO-AXIAL CABLES.

To remedy these cases one always needs to take the co-axial cable away HORIZONTALLY from the system until one is at least 2 meters from the nearest antenna, then take the cables up along the wall if needed.

A typical problem in slaved systems which are not installed this way may be the presence of a "continuous" tag signal and/or a rather high noise level.

We find time and time again that all systems that do not perform well, were simply NOT ABLE to work well because of improper installation.

The only way to cure these problem cases is to carefully study the procedures once more and check if the installation concerned meets all requirements.

After having made the necessary changes (even if this would mean changing the antenna-positions) you will see that the problems you had in the beginning have completely disappeared.

A bad position of the system or poor installation CANNOT be compensated by changing adjustments.

ALIGNMENT OF SYSTEMS "FROM SCRATCH"

GENERAL INFORMATION

The alignment of QF systems as explained in the following pages should normally not be necessary.

Every complete system is delivered pre-aligned and should not need any aligning with exception of the few adjustments discussed in part 1 of this manual.

When a system is assembled from parts or a module is replaced it may be necessary to follow the procedures for a complete alignment.

To be able to do this we need:

- 1> System checker TLT 75
- 2> Oscilloscope with 10:1 probe, freq. range 15 MHz.min.

ADJUSTMENT IN THE RIGHT ORDER

At all times it is very important to follow the procedures in the right order as some alignments are influenced by others.

- 1 - Make sure that all frequency jumpers are in the desired position.
There are 3 frequency jumpers:
 - Jumper 1: at the bottom of TX module 1 (TM1) HF/LF OSCILLATOR.
 - Jumper 2: next to the antenna connector on the Transmitter board (TX).
 - Jumper 3: beneath the antenna connector on the Receiver board (RX).All jumpers are marked "3-5-8" and all 3 jumpers must always be in the same position.
- 2 - Using the system checker, adjust the frequency at the desired frequency and adjust the sweepwidth at maximum 10% of center frequency.
- 3 - Connect the probe-tip of the oscilloscope to the probe ground-clamp, (to create a closed loop) and hold it in the transmitter antenna.
This way the probe is an antenna and we are able to pick up the HF-signal transmitted by the transmitter.

On the oscilloscope should be an image visible that equals Fig. 2 or Fig. 3.

Adjust the HF transmitter signal by using the TX rotary switch "TRIM". This signal should be as high as possible (Peak to Peak value) and as flat as possible. See Fig. 3 for correct adjustment.

- 4 - Put the jumper "MAN/AUTO" on the RX-board on "MAN".
The "GAIN"-potmeter on the RX-board can be used for adjusting the sensitivity manually. (until LED level on RM3 is starting to glow.)
- 5 - Connect the oscilloscope to RX-TP3.
On the oscilloscope should be an image visible that equals Fig. 4 or Fig. 5.
With the "GAIN"-potmeter on the receiver we can make this signal larger or smaller. (Sensitivity)
Adjust the LF receiver signal by using the RX antenna-trimmer "TRIM". This signal should be a double-sinewave shaped signal.
See Fig. 5 for the correct adjustment.
After adjusting the antenna trim the led at RM4 marked LABEL is probably lightning. This means that the antenna adjustment has be changed after powering up the system. **When the led marked Label at RM4 is lightning it is not possible to trigger an alarm with a tag.**
When this LED is lightning constantly longer than 7 seconds the system resets itself.
- 6 - Connect the oscilloscope to RX-TP5.
On the oscilloscope should be an image visible that equals Fig. 1.
- 7 - Switch off the power-supply and remove all tags that are close to the antennas.
Put the jumper "MAN/AUTO" on "AUTO" and switch the power-supply on.
Wait until the system has reached its most sensitive point.
(After a while of fast blinking the **GAIN-UP** led on RM4 should stop blinking)
Now the system has adjusted itself correctly.

NOTE: TAKE CARE THAT WHEN THE COVER IS PUT ON THAT THE JUMPER "GAIN MAN/AUTO" IS ON THE POSITION **AUTO!**

The system is now ready for use and the sensitivity can be checked by moving a tag towards the system.

Hold a tag at breast-height and walk towards the system.

If the system alarms when you are about 40 centimeters away from the system, the sensitivity is good.

If the system does not alarm, check the adjustments by going through this adjustment procedure again.

DETECTION ACCURACY

In the micro processor beneath the AGC module the "heart" of the system is located. This processor determines whether the detected signal is a label signal or not.

In case of a label signal the processor will give an alarm signal and the alarm will go off.

The accuracy of detection depends on the position of the jumper "PER".

On position "4" the accuracy is minimum, on position "8" the accuracy is maximum.

Factory setting is "6".

BEEPER TIME

The beep time can be adjusted with the jumper called "BEEP"

NOTE:

The jumper settings become active after power reset.

ADJUSTMENTS AT THE BOTTOM SIDE OF THE MODULES



MODULE TM1:

WITH THE JUMPER THE FREQUENCY CAN BE ADJUSTED.

2 = 1,95 MHz

3 = 3,25 MHz

5 = 4,75 MHz

8 = 8,2 MHz

10 = 10 MHz



MODULE RM2:

(STANDARD **ON**)

WHEN THERE IS AN CONSTANT BLANKING SIGNAL IS PRESENT WHICH NOT EFFECT THE LABEL DETECTION BUT DOES EFFECT THE GAIN TOO MUCH, THE JUMPER CAN BE SET TO **OFF**. THE AUTOMATIC GAIN CONTROL IS THAN NO LONGER EFFECTED BY THE BLANKING SIGNAL OUTPUT.

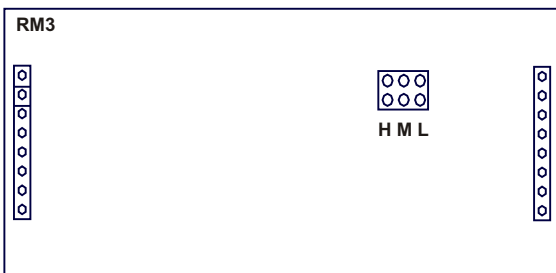

MODULE RM3:

SENSITIVITY FOR TAG SIGNALS ADJUSTMENT.
(STANDARD **M**)

H = HIGH SENSITIVITY BUT MORE CHANCES FOR FALSE OR PHANTOM ALARMS.

M = STANDARD (MID) SENSITIVITY.

L = LOW SENSITIVITY.

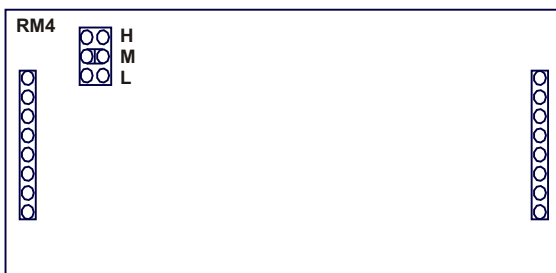

MODULE RM4:

ADJUSTMENT FOR DETECTION OF METAL OBJECTS WHO CAN CAUSE A FALSE ALARM. (STANDARD **M**)

H = HIGH SENSITIVITY FOR METAL OBJECTS.

M = STANDARD (MID) SENSITIVITY.

L = LOW SENSITIVITY.

BEFORE MODULES ARE REMOVED BE SURE THAT THE POWER IS OFF

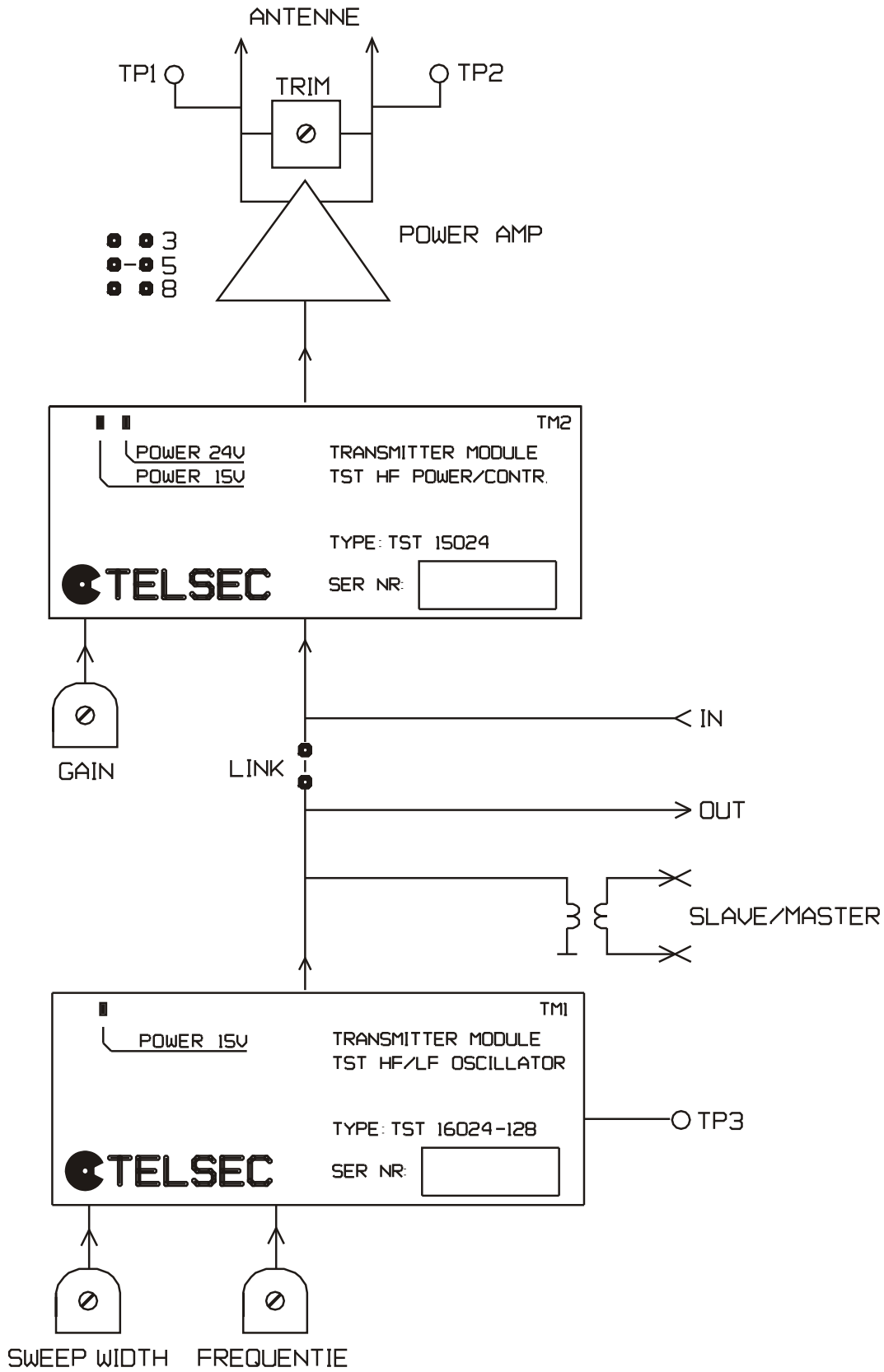

DRAWING: 1:1

SUBJECT: TRANSM. BLOCKDIAGR.

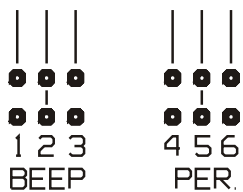
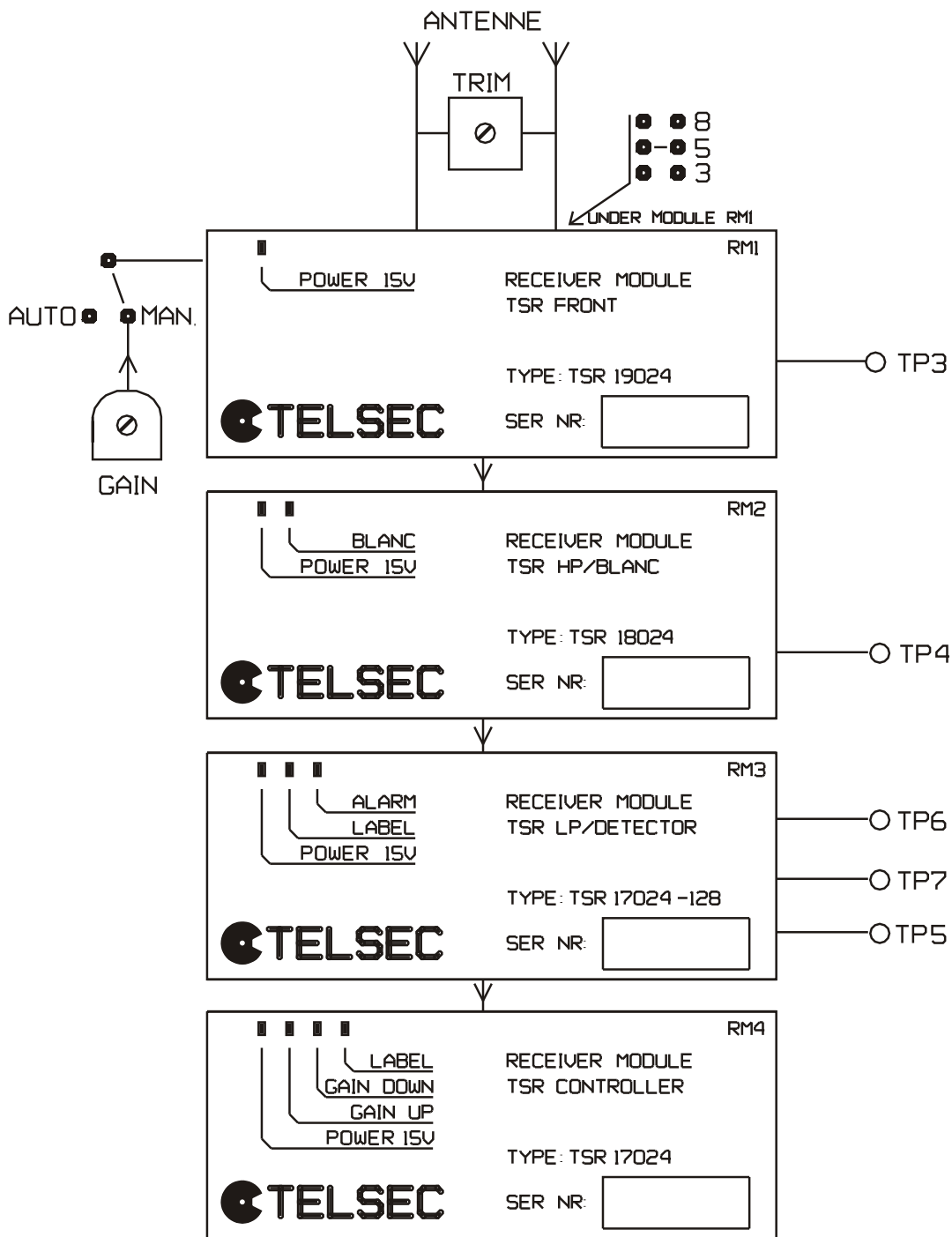

DRAWING: 1:2

SUBJECT: RECEIVER. BLOCKDIAGR.

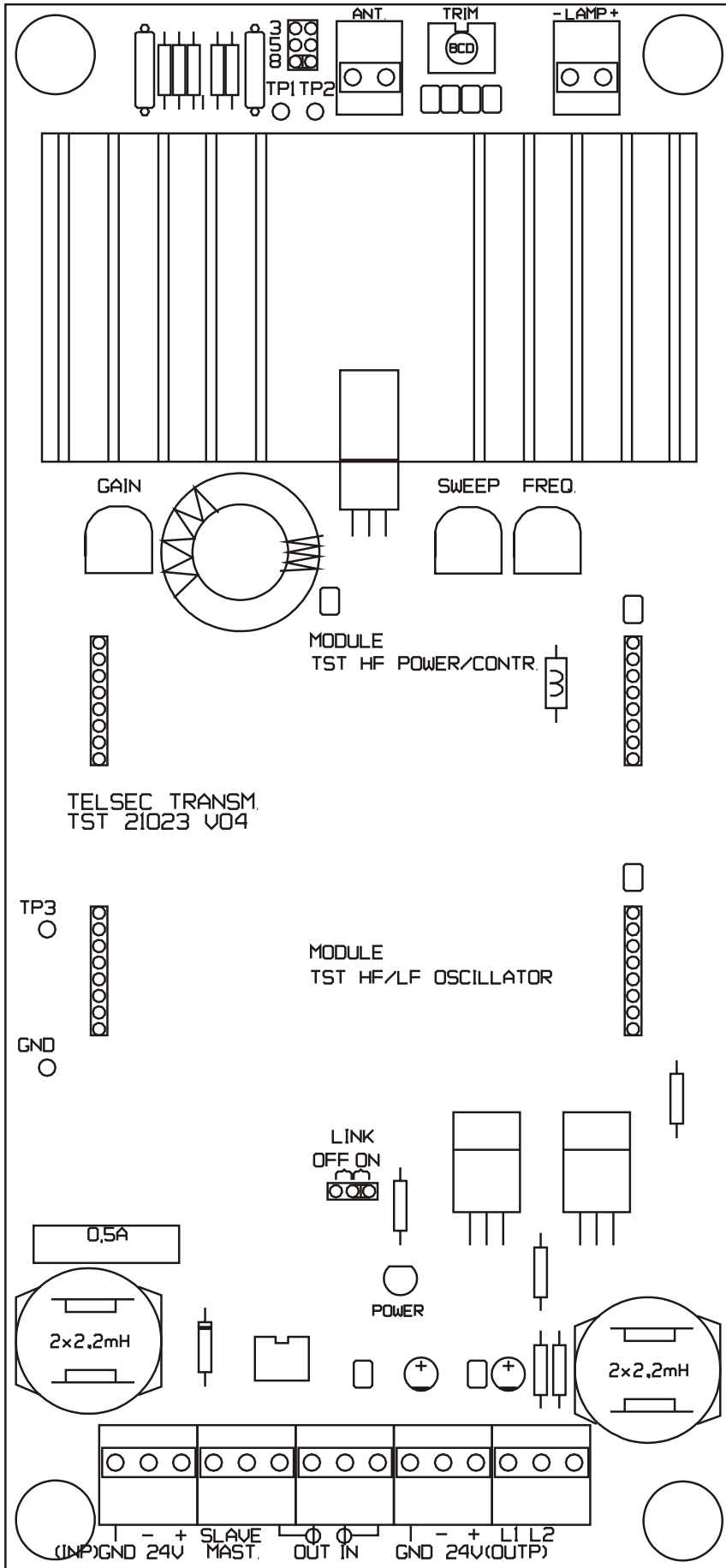

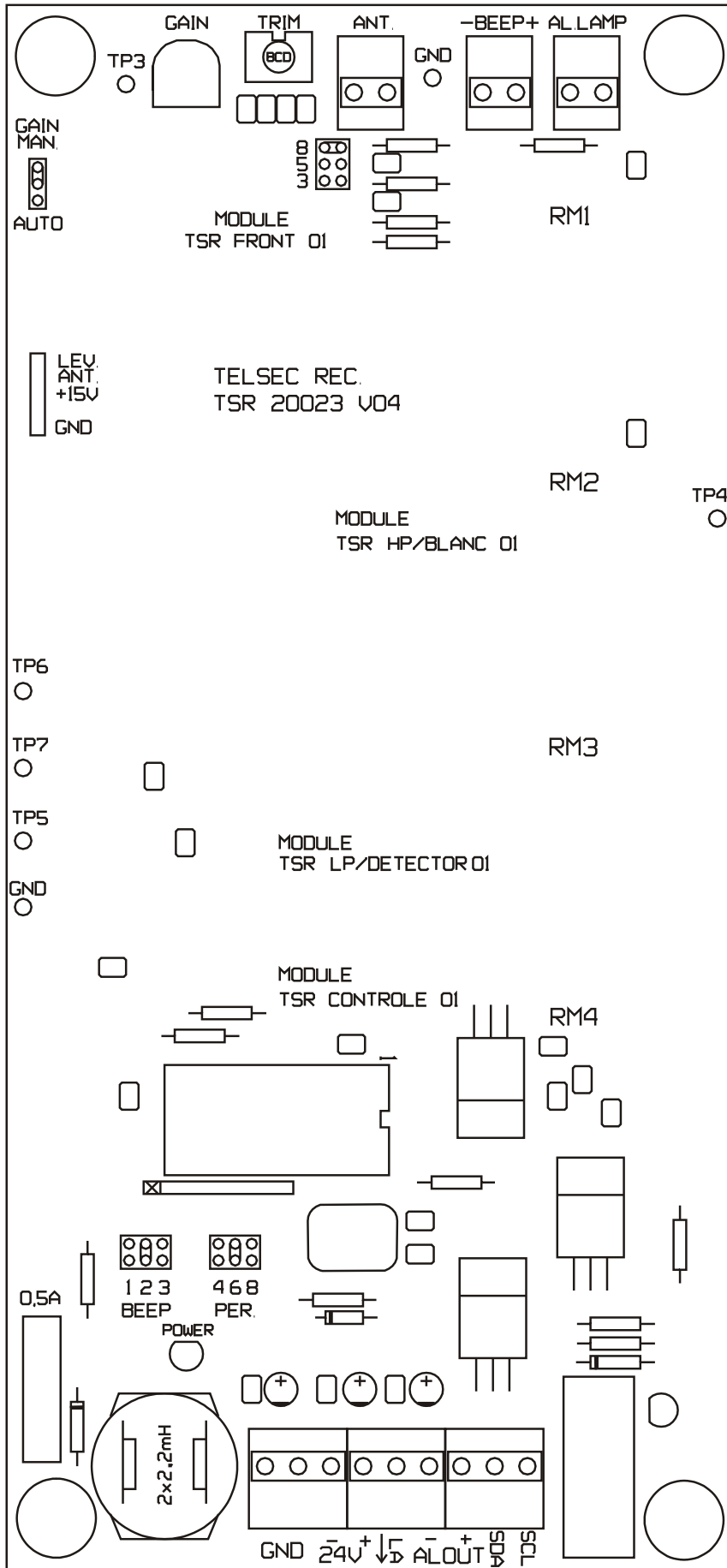

DRAWING: 1:4

SUBJECT: RECEIVER. LAYOUT.





2000 - SYSTEM

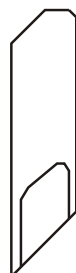
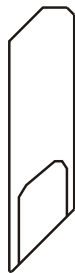

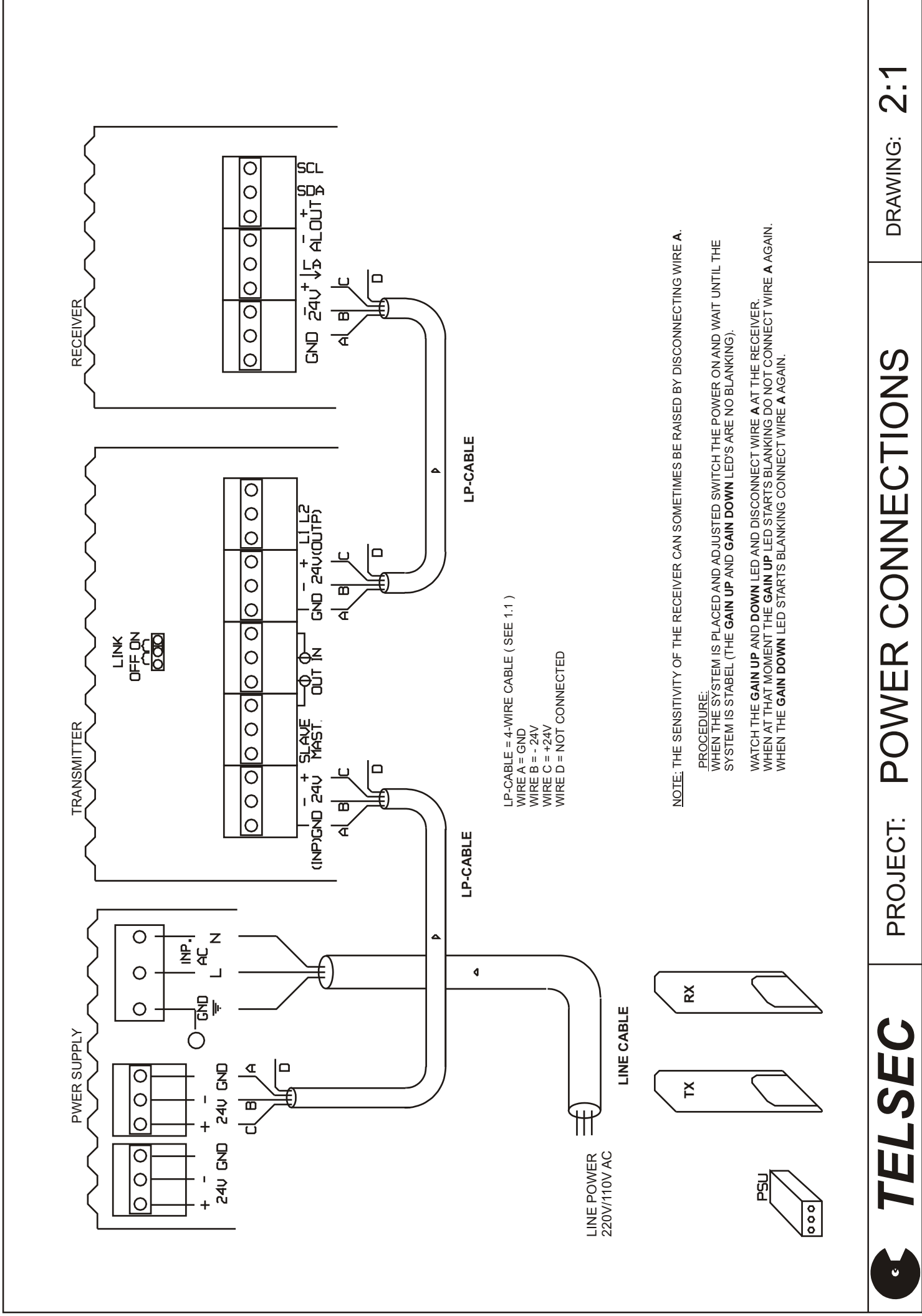

PROJECT: **POWER CONNECTIONS**

DRAWING: **2:1**

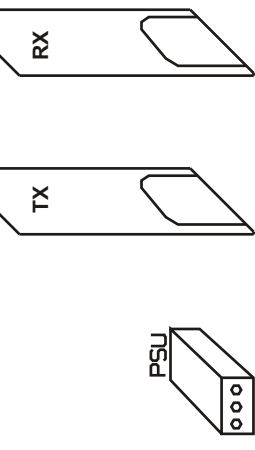

NOTE: THE SENSITIVITY OF THE RECEIVER CAN SOMETIMES BE RAISED BY DISCONNECTING WIRE A.

PROCEDURE:
 WHEN THE SYSTEM IS PLACED AND ADJUSTED SWITCH THE POWER ON AND WAIT UNTIL THE SYSTEM IS STABLE (THE **GAIN UP** AND **GAIN DOWN** LED'S ARE NO BLANKING).
 WATCH THE **GAIN UP** AND **DOWN** LED AND DISCONNECT WIRE A AT THE RECEIVER.
 WHEN AT THAT MOMENT THE **GAIN UP** LED STARTS BLANKING DO NOT CONNECT WIRE A AGAIN.
 WHEN THE **GAIN DOWN** LED STARTS BLANKING CONNECT WIRE A AGAIN.

LP-CABLE = 4-WIRE CABLE (SEE 1.1)
 WIRE A = GND
 WIRE B = - 24V
 WIRE C = +24V
 WIRE D = NOT CONNECTED

LINE POWER
220V/110V AC

LINE CABLE

LP-CABLE

LP-CABLE

POWER SUPPLY

TRANSMITTER

RECEIVER

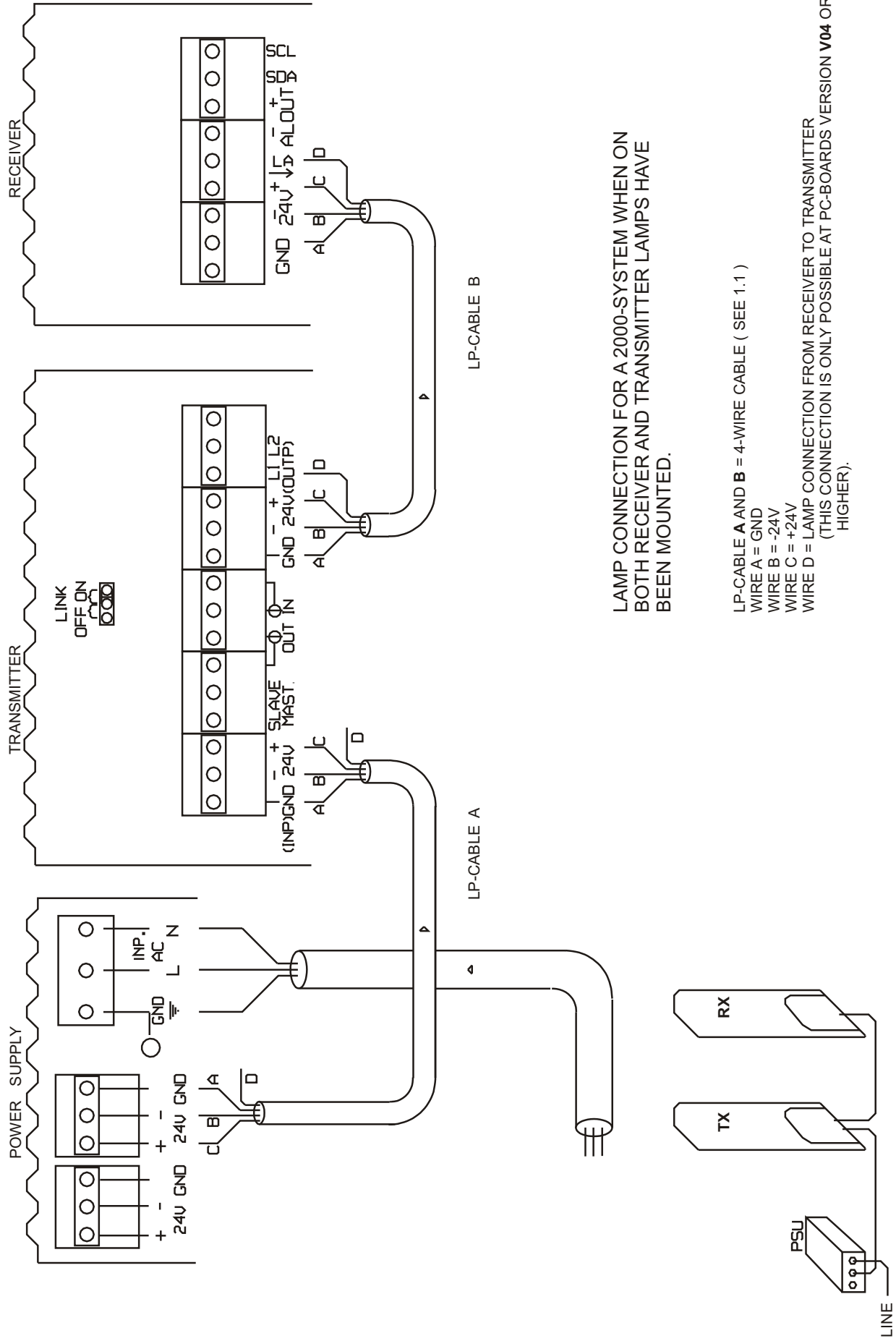

LAMP CONNECTION FOR A 2000-SYSTEM WHEN ON BOTH RECEIVER AND TRANSMITTER LAMPS HAVE BEEN MOUNTED.

LP-CABLE A AND B = 4-WIRE CABLE (SEE 1.1)
 WIRE A = GND
 WIRE B = -24V
 WIRE C = +24V
 WIRE D = LAMP CONNECTION FROM RECEIVER TO TRANSMITTER
 (THIS CONNECTION IS ONLY POSSIBLE AT PC-BOARDS VERSION V04 OR HIGHER).

TRANSMITTER

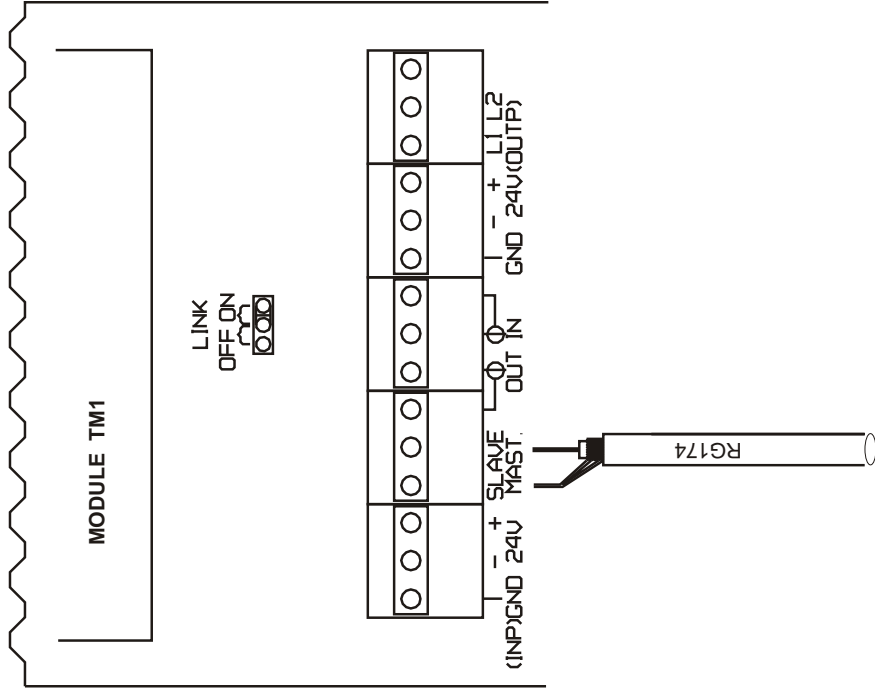

FROM ANOTHER TRANSMITTER OR
A CSU UNIT

SYNCHRONISATION OF A SYSTEM IS NECESSARY WHEN AN OTHER SYSTEM WHICH WORKS AT THE SAME FREQUENCY CAN INTERFERE WITH THE SYSTEM PLACED IN AN AREA WHERE THEY CAN "SEE" EACH OTHER.

TO AVOID THESE PROBLEMS THERE MUST BE A CONNECTION OF A SO CALLED MASTER UNIT (THIS CAN BE AN OTHER TRANSMITTER OR A CSU) TO THE 2000-SYSTEM.

THIS MUST BE DONE BY A COAX WIRE (SEE 1.1).

MODULE **TM1** MUST BE REMOVED.

LINK IS CONNECTED TO **ON**.

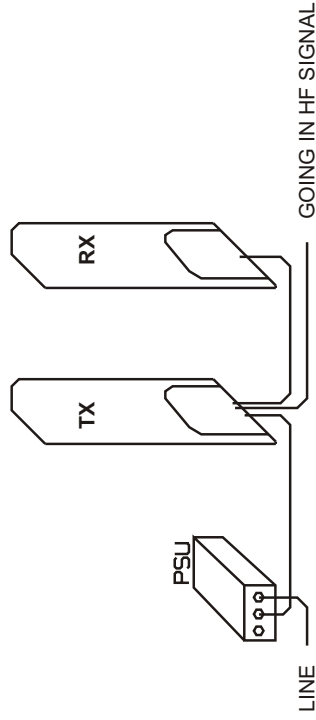

TRANSMITTER

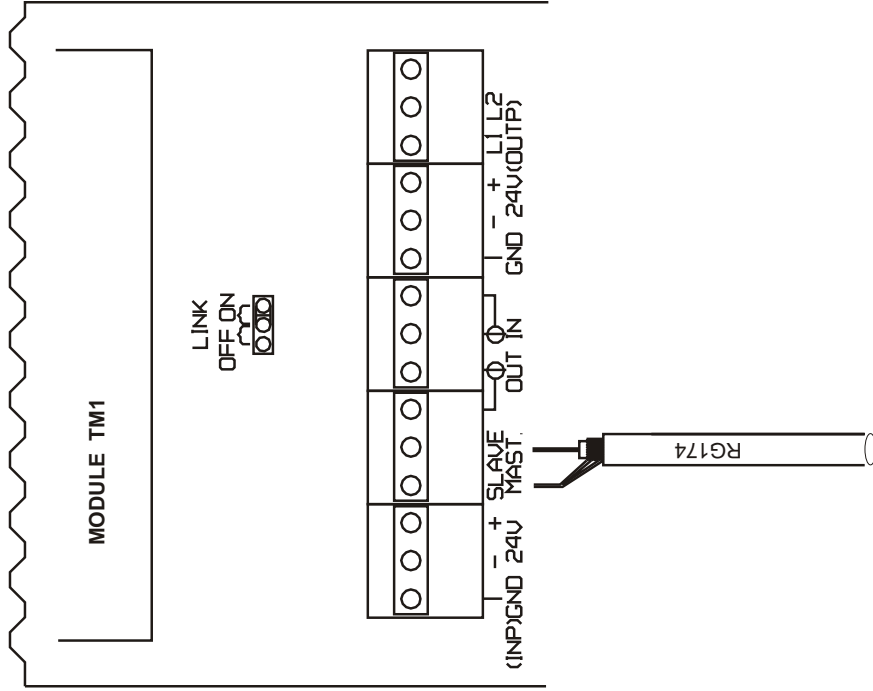

TO AN OTHER TRANSMITTER OR
A STICKERDEACTIVATOR UNIT

SYNCHRONISATION OF A SYSTEM IS NECESSARY WHEN AN OTHER SYSTEM WHICH WORKS AT THE SAME FREQUENCY CAN INTERFERE WITH THE SYSTEM PLACED IN AN AREA WHERE THEY CAN "SEE" EACH OTHER.

TO AVOID THESE PROBLEMS THERE MUST BE A CONNECTION OF A SO CALLED MASTER UNIT TO A SLAVE UNIT.

THIS MUST BE DONE BY A COAX WIRE (SEE 1.1).

IN THIS SITUATION THE TRANSMITTER FUNCTIONS AS THE MASTER UNIT. AT THE OTHER END OF THE COAX IT IS POSSIBLE TO CONNECT AN OTHER 2000-SYSTEM OR A STICKERDEACTIVATOR UNIT WHICH FUNCTIONS AS A SLAVE UNIT.

LINK IS CONNECTED TO ON.

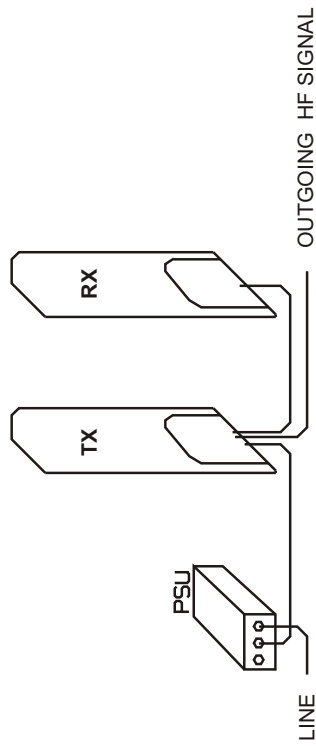

TRANSMITTER

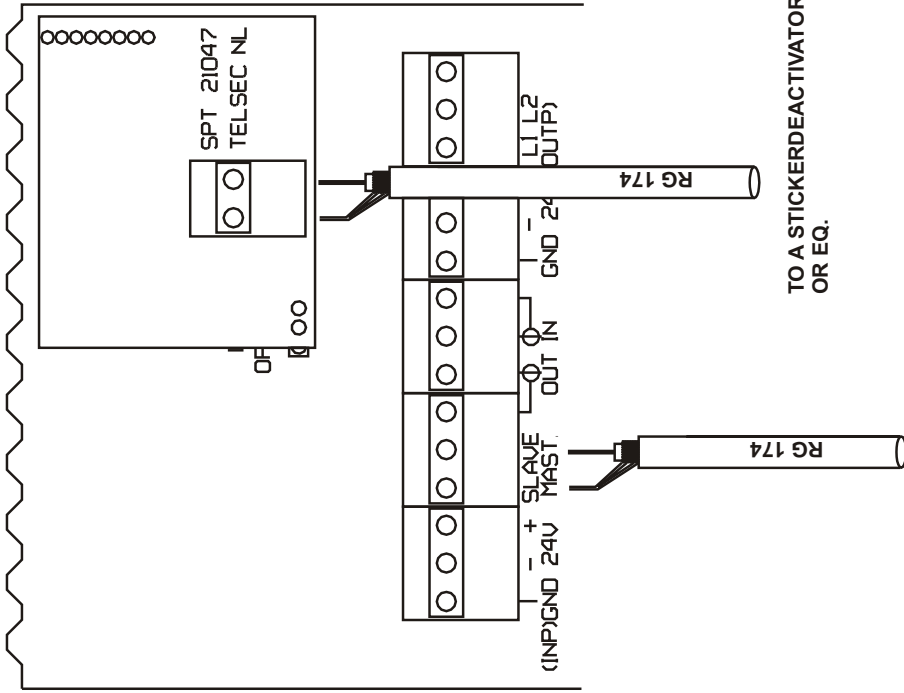

FROM AN OTHER TRANSMITTER OR CSU UNIT.

TO A STICKERDEACTIVATOR UNIT OR EQ.

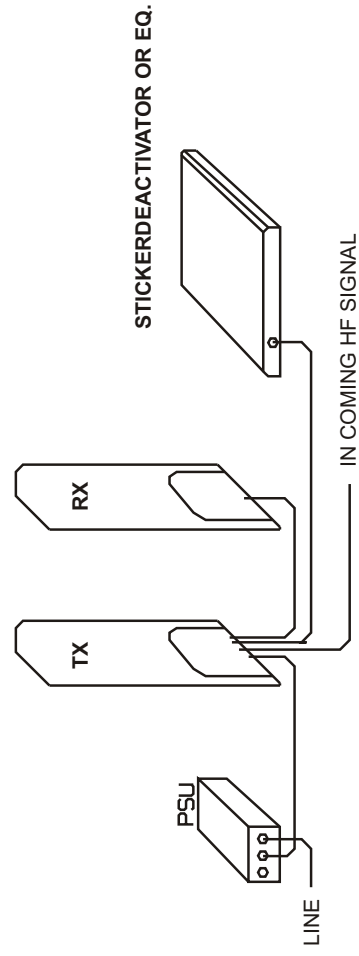

BY USING A SPECIAL UNIT (SPT 21047) A STICKERDEACTIVATOR UNIT CAN BE SYNCHRONIZED TOO, EVEN IF THE TRANSMITTER ITSELF IS ALREADY SYNCHRONIZED BY AN OTHER MASTER OR CSU UNIT.

PROCEDURE:

THE MODULE TM1 MUST BE REMOVED THE JUMPER ON THE LINK CONNECTOR MUST BE REMOVED. PLACE THE UNIT SPT21047 ON BOTH THE ON PINS OF THE LINK CONNECTOR AND THE 8-POL. CONNECTOR IN THE TM1 MODULE CONNECTOR.

PLACE THE COAX OUTPUT CABLE ON THE CONNECTOR OF THE SPT 21047 UNIT.



3000 - SYSTEM

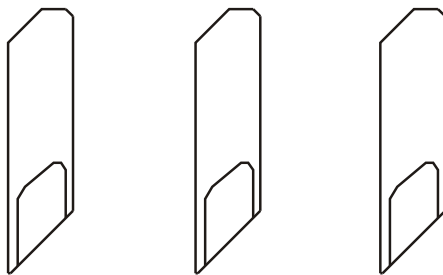

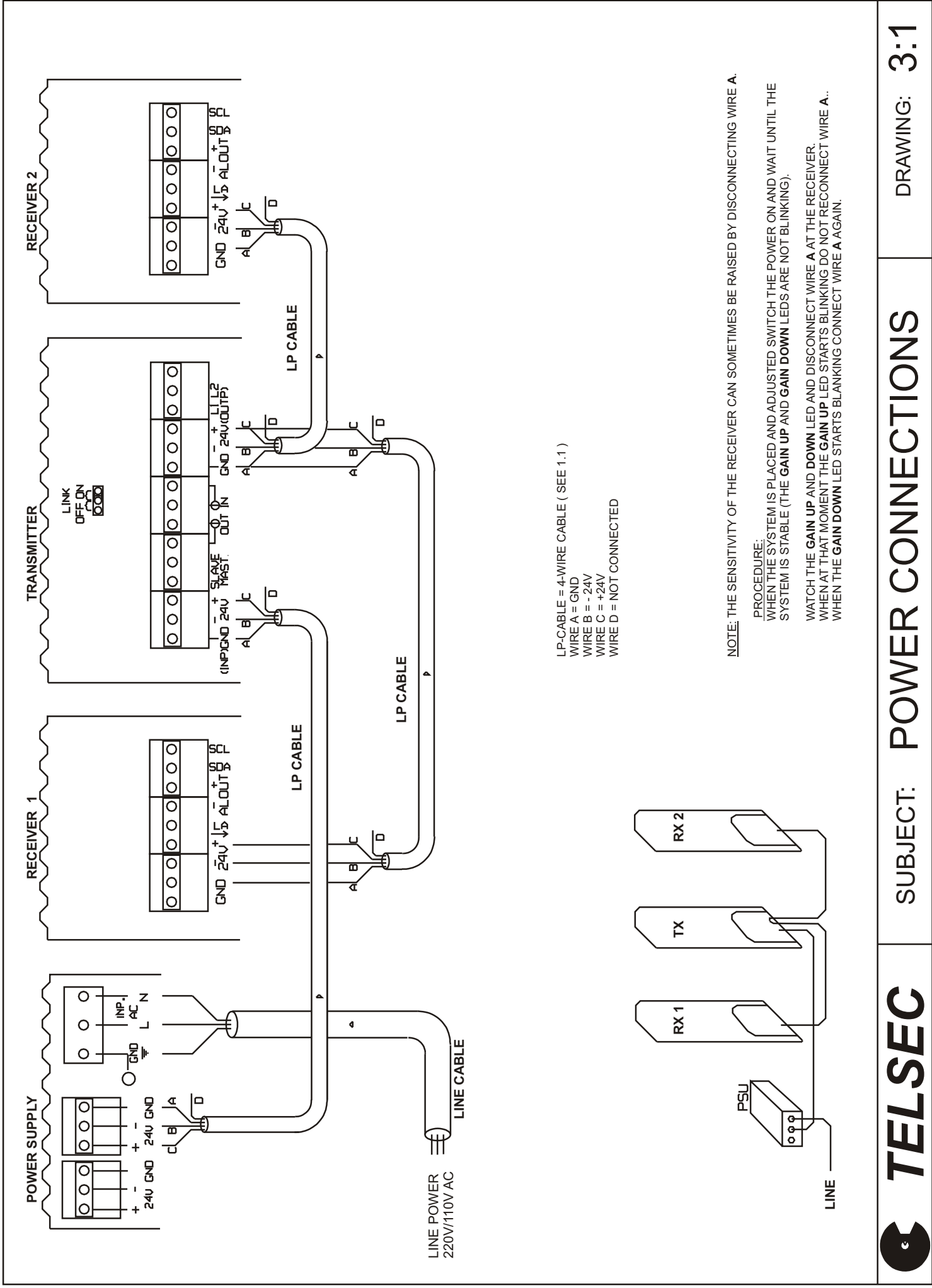

LP-CABLE = 4-WIRE CABLE (SEE 1.1)
 WIRE A = GND
 WIRE B = -24V
 WIRE C = +24V
 WIRE D = NOT CONNECTED

NOTE: THE SENSITIVITY OF THE RECEIVER CAN SOMETIMES BE RAISED BY DISCONNECTING WIRE A.
PROCEDURE:
 WHEN THE SYSTEM IS PLACED AND ADJUSTED SWITCH THE POWER ON AND WAIT UNTIL THE SYSTEM IS STABLE (THE **GAIN UP** AND **GAIN DOWN** LEADS ARE NOT BLINKING).
 WATCH THE **GAIN UP** AND **DOWN** LED AND DISCONNECT WIRE A AT THE RECEIVER.
 WHEN AT THAT MOMENT THE **GAIN UP** LED STARTS BLINKING DO NOT RECONNECT WIRE A..
 WHEN THE **GAIN DOWN** LED STARTS BLINKING RECONNECT WIRE A AGAIN.

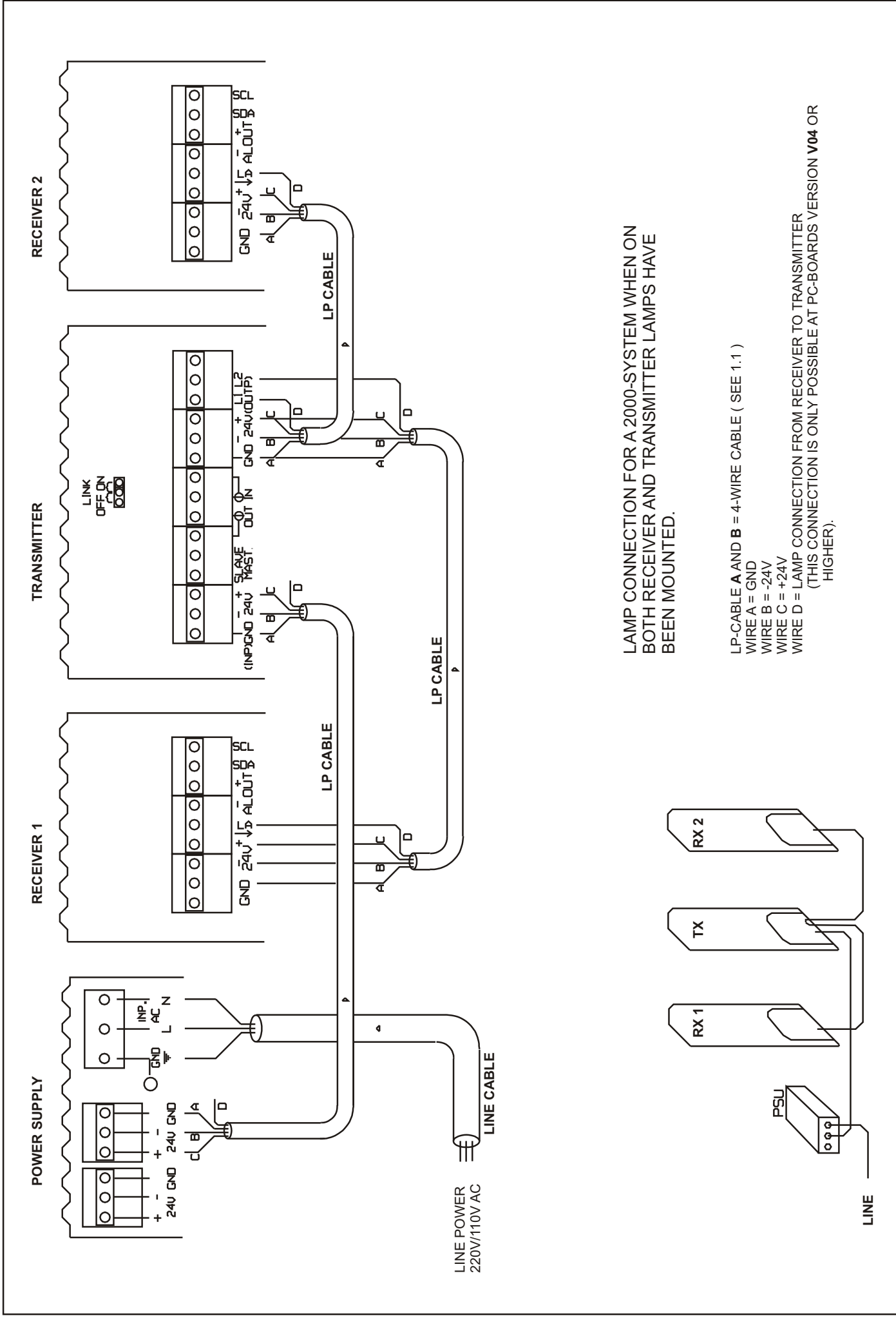

LAMP CONNECTION FOR A 2000-SYSTEM WHEN ON BOTH RECEIVER AND TRANSMITTER LAMPS HAVE BEEN MOUNTED.

- LP-CABLE A AND B = 4-WIRE CABLE (SEE 1.1)
- WIRE A = GND
- WIRE B = -24V
- WIRE C = +24V
- WIRE D = LAMP CONNECTION FROM RECEIVER TO TRANSMITTER (THIS CONNECTION IS ONLY POSSIBLE AT PC-BOARDS VERSION V04 OR HIGHER).

TRANSMITTER

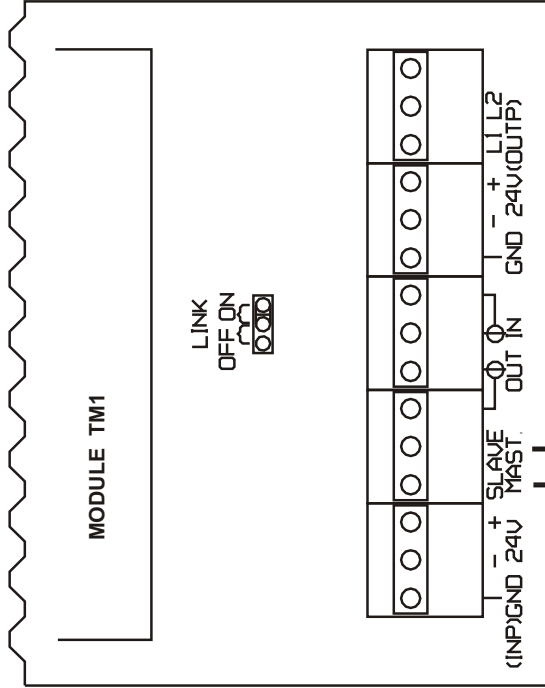

SYNCHRONISATION OF A SYSTEM IS NECESSARY WHEN AN OTHER SYSTEM WHICH WORKS AT THE SAME FREQUENCY CAN INTERFERE WITH THE SYSTEM PLACED IN AN AREA WHERE THEY CAN "SEE" EACH OTHER.

TO AVOID THESE PROBLEMS THERE MUST BE A CONNECTION OF A SO CALLED MASTER UNIT (THIS CAN BE AN OTHER TRANSMITTER OR A CSU) TO THE 2000-SYSTEM.

THIS MUST BE DONE BY A COAX WIRE (SEE 1.1).

MODULE **TM1** MUST BE REMOVED.

LINK IS CONNECTED TO **ON**.

FROM ANOTHER TRANSMITTER OR A CSU UNIT

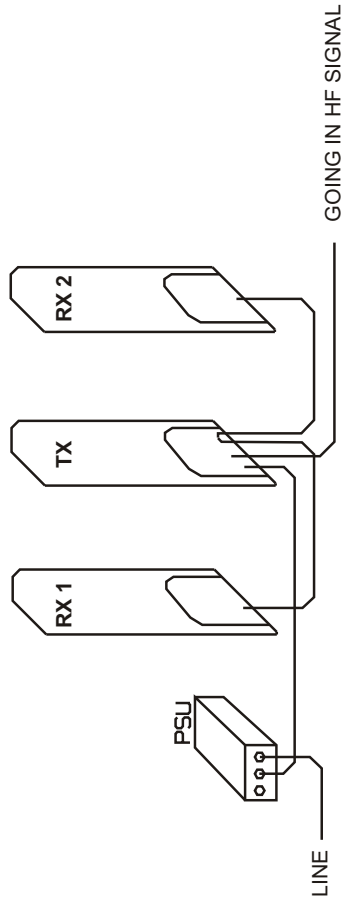

TRANSMITTER

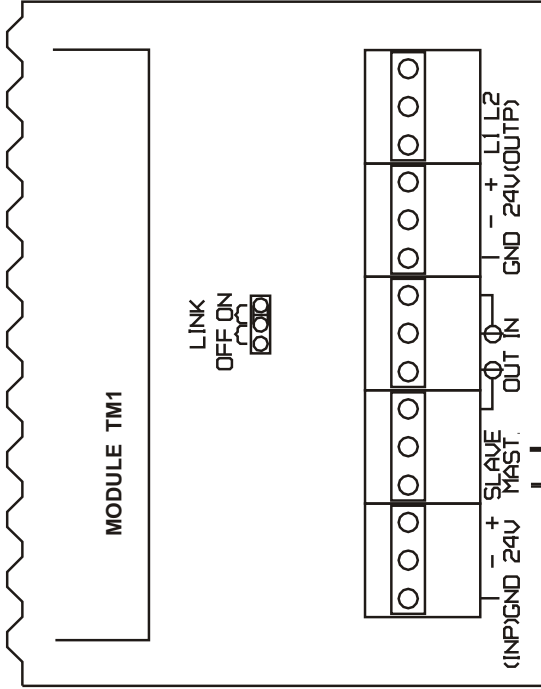

TO AN OTHER TRANSMITTER OR
A STICKERDEACTIVATOR UNIT

SYNCHRONISATION OF A SYSTEM IS NECESSARY WHEN AN OTHER SYSTEM WHICH WORKS AT THE SAME FREQUENCY CAN INTERFERE WITH THE SYSTEM PLACED IN AN AREA WHERE THEY CAN "SEE" EACH OTHER.

TO AVOID THESE PROBLEMS THERE MUST BE A CONNECTION OF A SO CALLED MASTER UNIT TO A SLAVE UNIT.

THIS MUST BE DONE BY A COAX WIRE (SEE 1.1).

IN THIS SITUATION THE TRANSMITTER FUNCTIONS AS THE MASTER UNIT. AT THE OTHER END OF THE COAX IT IS POSSIBLE TO CONNECT AN OTHER 2000-SYSTEM OR A STICKERDEACTIVATOR UNIT WHICH FUNCTIONS AS A SLAVE UNIT.

LINK IS CONNECTED TO ON.

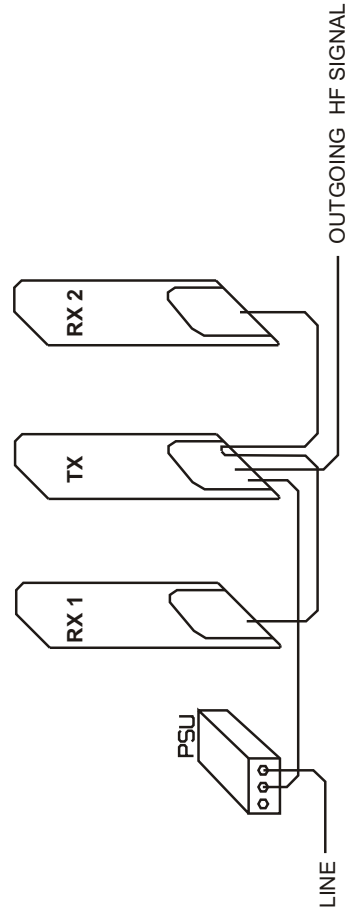

TRANSMITTER

LINK
OFF ON

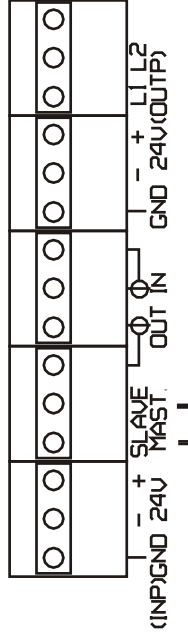

TO A STICKERDEACTIVATOR UNIT
OR EQ.

PROCEDURE:

CHANGE THE SETTINGS OF THE STICKERDEACTIVATOR FROM MASTER TO SLAVE.

STICKERDEACTIVATOR OR EQ.

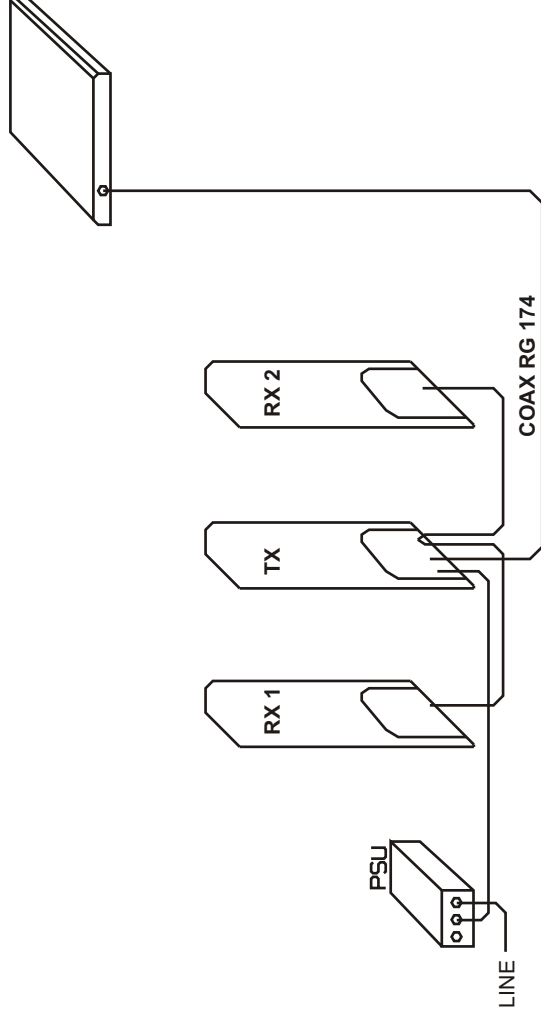

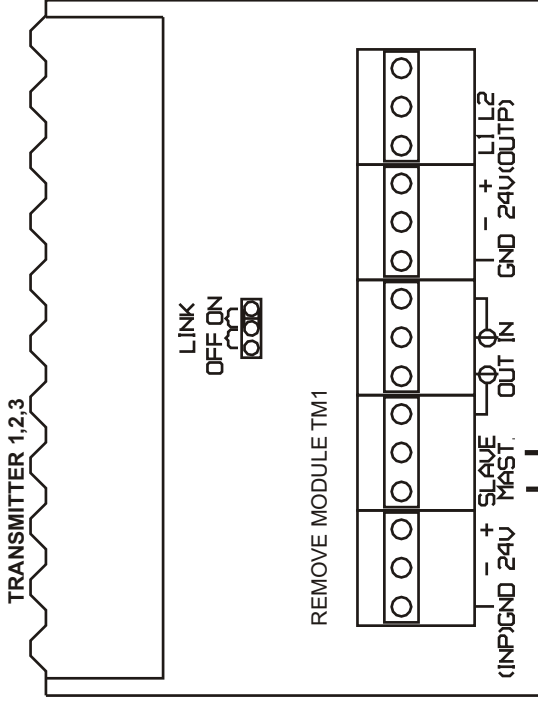

COAX CABLE WHICH IS TO LONG HAS TO BE FOULDED LIKE BELOW AND PLACED IN TX-BOX



COAX 1 OR 2 OR 3.

RG174

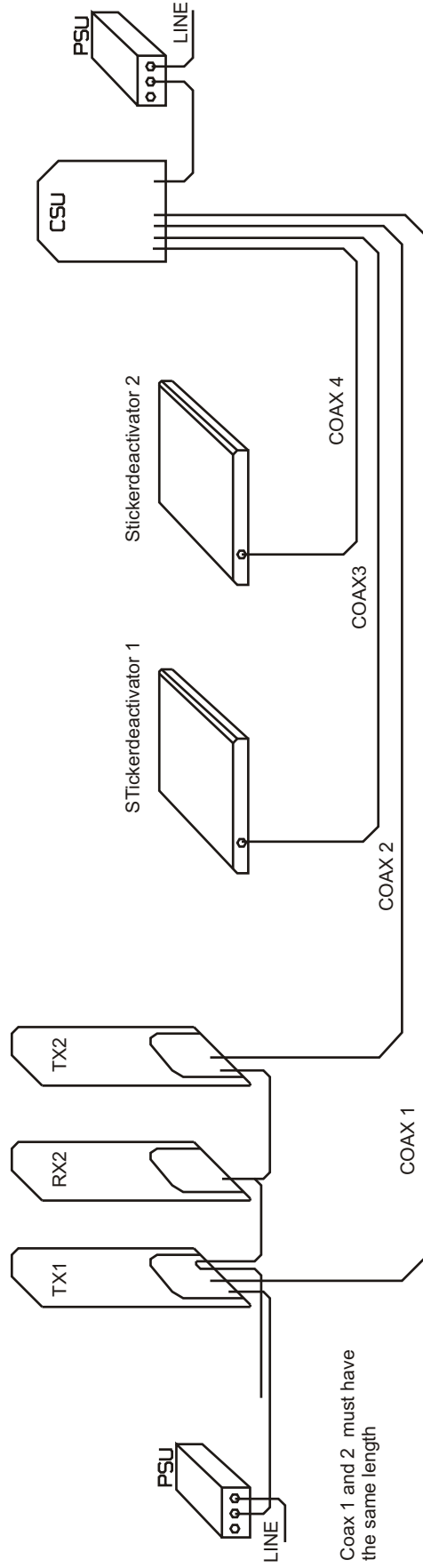

Coax 1 and 2 must have the same length



4000 - SYSTEM

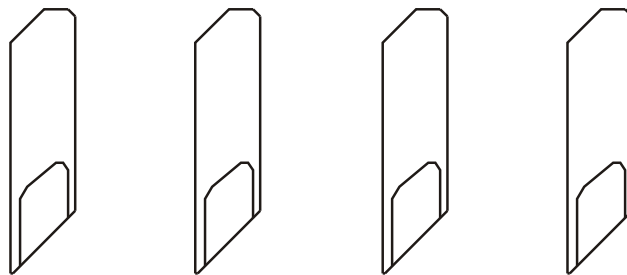

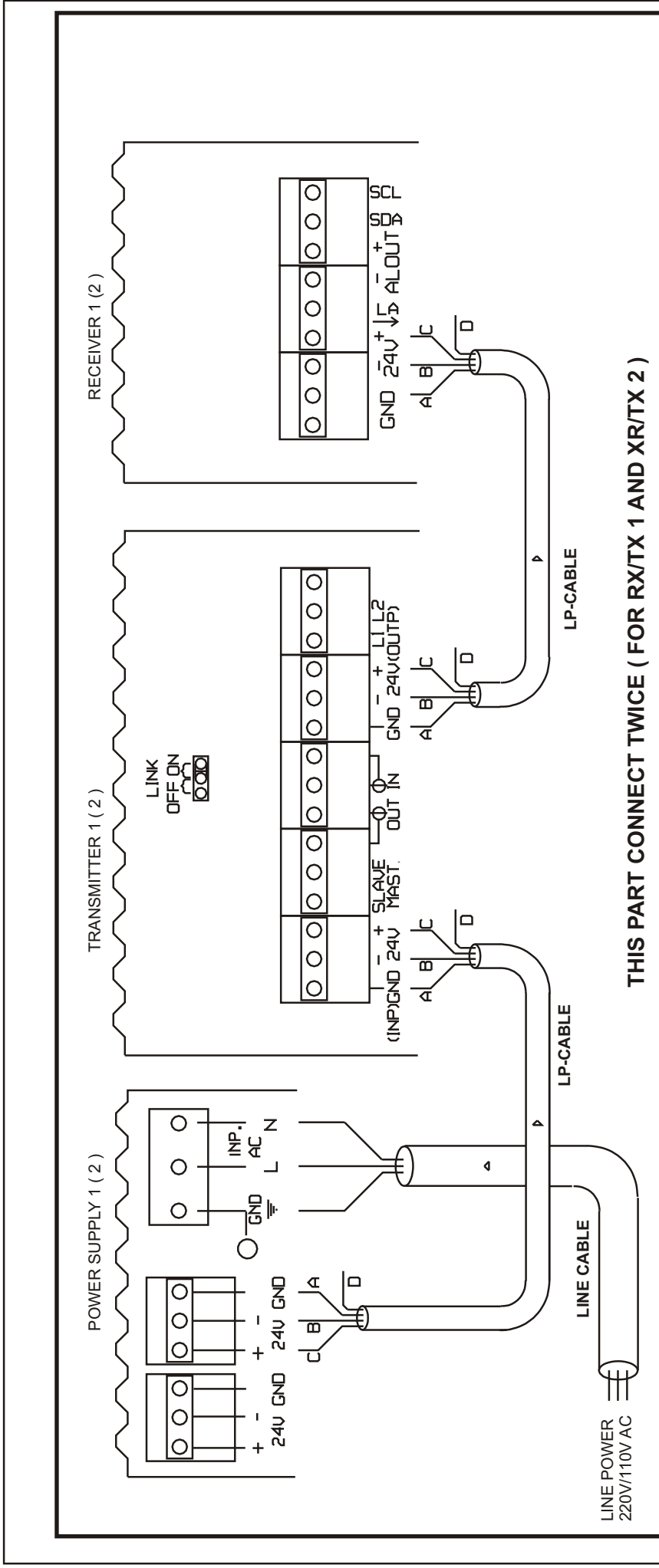

THIS PART CONNECT TWICE (FOR RX/TX 1 AND XR/TX 2)

LP-CABLE = 4-WIRE CABLE (SEE 1.1)
 WIRE A = GND
 WIRE B = - 24V
 WIRE C = +24V
 WIRE D = NOT CONNECTED

NOTE: THE SENSITIVITY OF THE RECEIVER CAN SOMETIMES BE RAISED BY DISCONNECTING WIRE A.

PROCEDURE:
 WHEN THE SYSTEM IS PLACED AND ADJUSTED SWITCH THE POWER ON AND WAIT UNTIL THE SYSTEM IS STABLE (THE GAIN UP AND GAIN DOWN LEDS ARE NOT BLINKING).
 WATCH THE GAIN UP AND DOWN LED AND DISCONNECT WIRE A AT THE RECEIVER.
 WHEN AT THAT MOMENT THE GAIN UP LED STARTS BLINKING DO NOT RECONNECT WIRE A..
 WHEN THE GAIN DOWN LED STARTS BLANKING CONNECT WIRE A AGAIN.

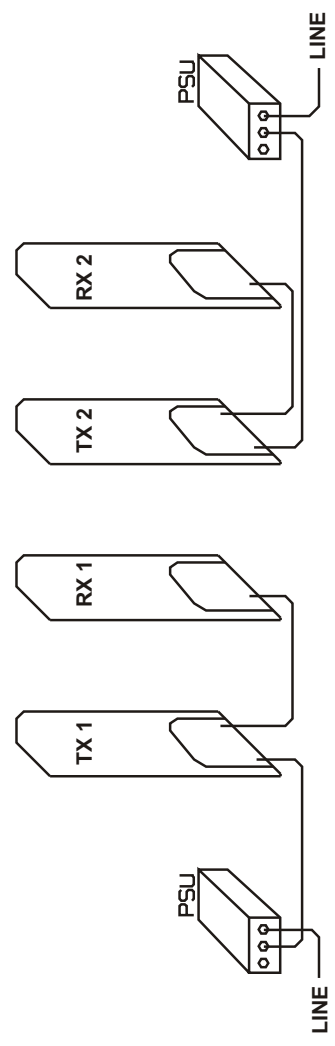

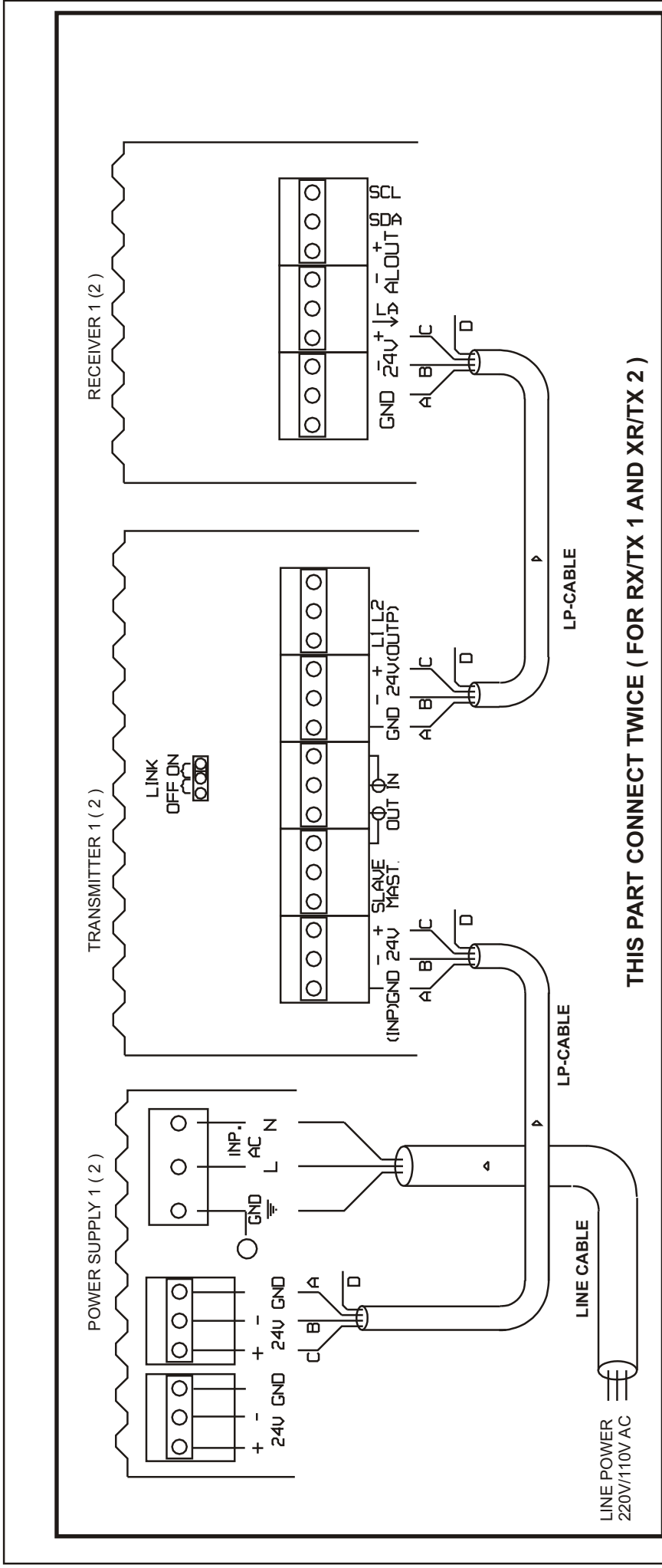

IN THIS SITUATION LAMP CONNECTION FROM RECEIVER TO TRANSMITTER IS NOT USEFULL BECAUSE THE SYSTEM CAN NOT DETERMINE OF WHICH SIDE OF THE RECEIVER THE TAG IS DETECTED.
 ONLY THE RECEIVER LAMP IS BLINKING.

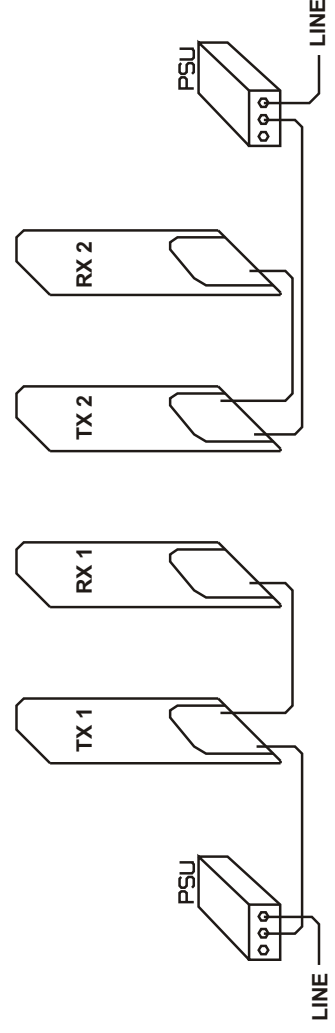

LP-CABLE = 4-WIRE CABLE (SEE 1.1)
 WIRE A = GND
 WIRE B = - 24V
 WIRE C = +24V
 WIRE D = NOT CONNECTED

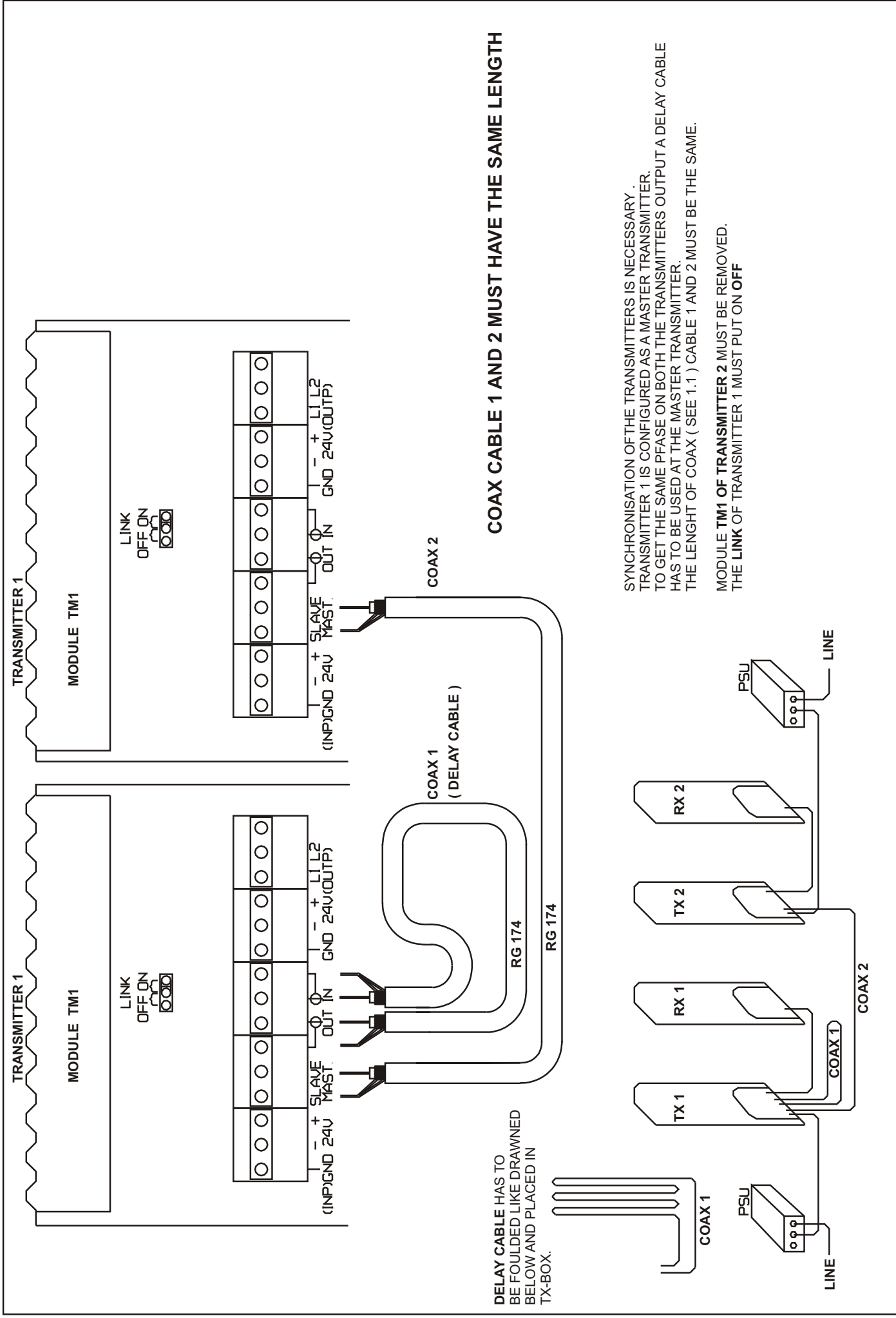

DELAY CABLE HAS TO BE FOULDED LIKE DRAWN BELOW AND PLACED IN TX-BOX.

COAX CABLE 1 AND 2 MUST HAVE THE SAME LENGTH

SYNCHRONISATION OF THE TRANSMITTERS IS NECESSARY. TRANSMITTER 1 IS CONFIGURED AS A MASTER TRANSMITTER. TO GET THE SAME PHASE ON BOTH THE TRANSMITTERS OUTPUT A DELAY CABLE HAS TO BE USED AT THE MASTER TRANSMITTER. THE LENGTH OF COAX (SEE 1.1) CABLE 1 AND 2 MUST BE THE SAME. MODULE TM1 OF TRANSMITTER 2 MUST BE REMOVED. THE LINK OF TRANSMITTER 1 MUST PUT ON OFF.





5000 - SYSTEM

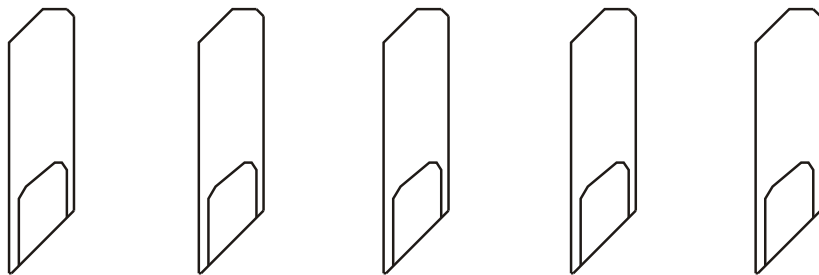

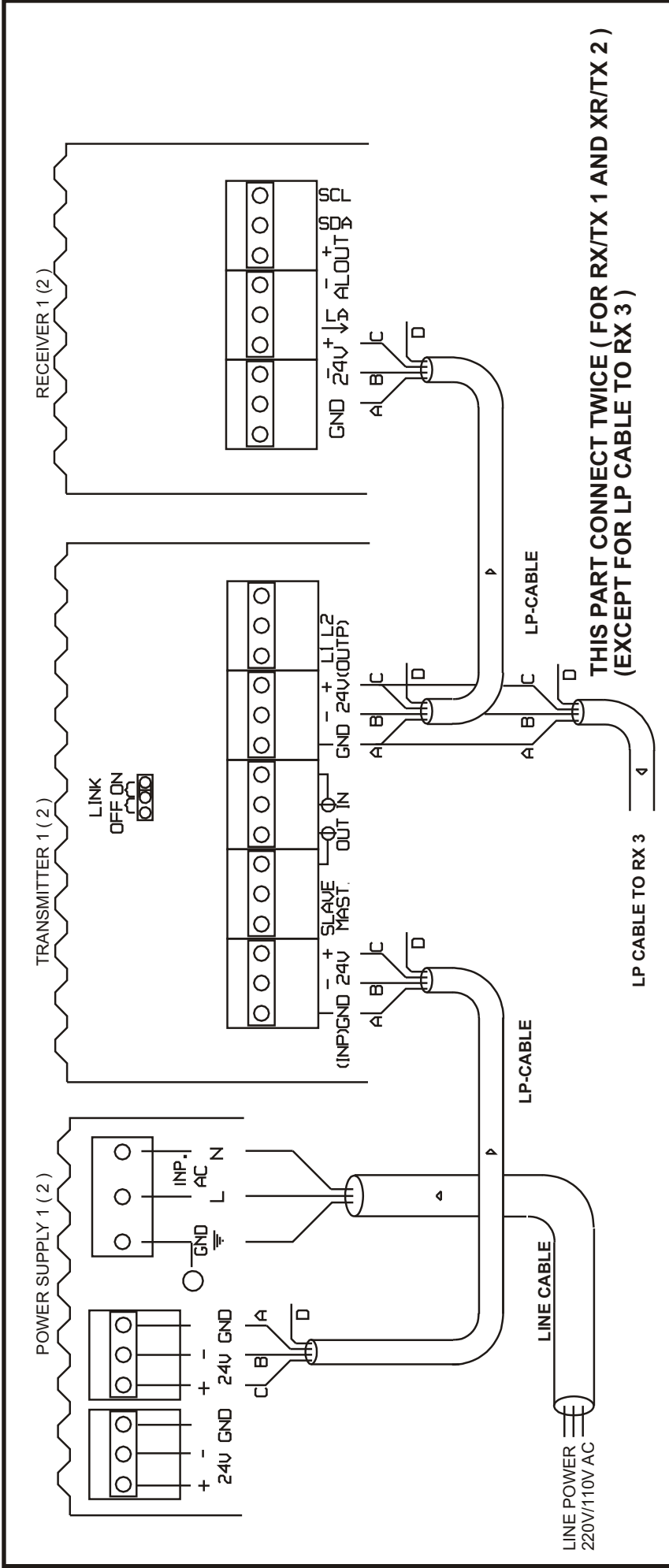

LP-CABLE = 4-WIRE CABLE (SEE 1.1)

WIRE A = GND

WIRE B = - 24V

WIRE C = +24V

WIRE D = NOT CONNECTED

NOTE: THE SENSITIVITY OF THE RECEIVER CAN SOMETIMES BE RAISED BY DISCONNECTING WIRE A.

PROCEDURE:

WHEN THE SYSTEM IS PLACED AND ADJUSTED SWITCH THE POWER ON AND WAIT UNTIL THE SYSTEM IS STABLE (THE GAIN UP AND GAIN DOWN LEDS ARE NOT BLINKING).

WATCH THE GAIN UP AND DOWN LED AND DISCONNECT WIRE A AT THE RECEIVER.

WHEN AT THAT MOMENT THE GAIN UP LED STARTS BLINKING DO NOT RECONNECT WIRE A.

WHEN THE GAIN DOWN LED STARTS BLINKING CONNECT WIRE A AGAIN.

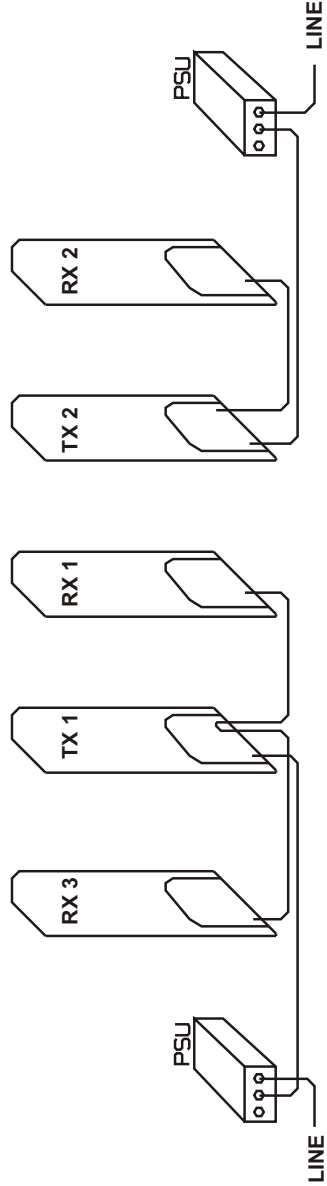

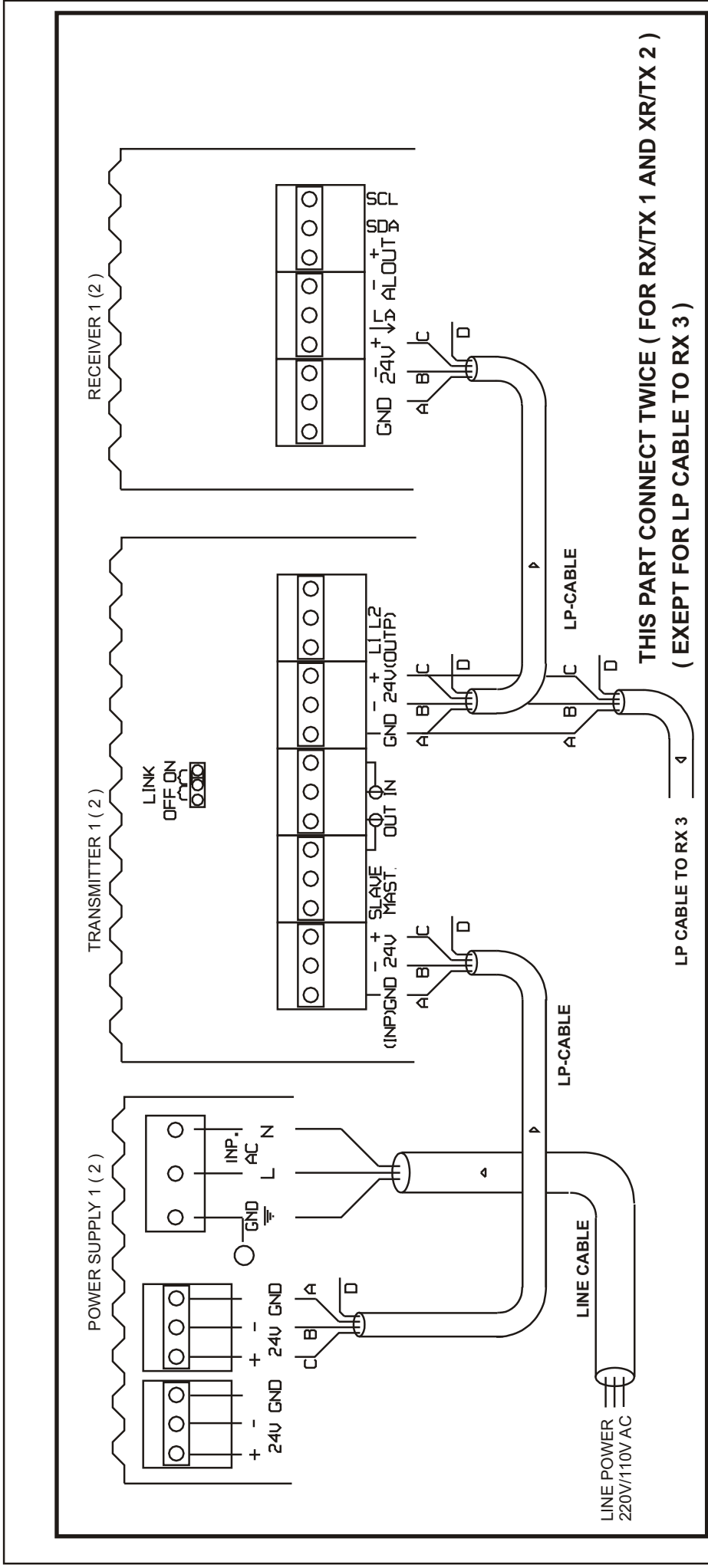

IN THIS SITUATION LAMP CONNECTION FROM RECEIVER TO TRANSMITTER IS NOT USEFULL BECAUSE THE SYSTEM CAN NOT DETERMINE OF WHICH SIDE OF THE RECEIVER THE TAG IS DETECTED.
ONLY THE RECEIVER LAMP IS BLINKING.

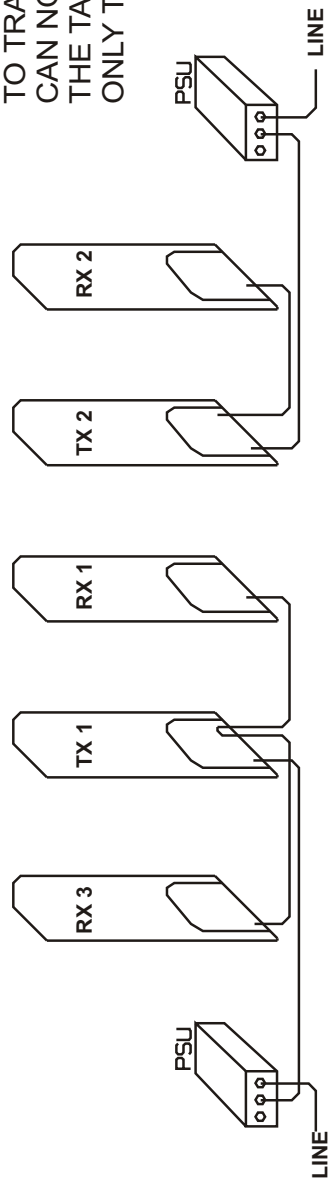

LP-CABLE = 4-WIRE CABLE (SEE 1.1)
WIRE A = GND
WIRE B = -24V
WIRE C = +24V
WIRE D = NOT CONNECTED

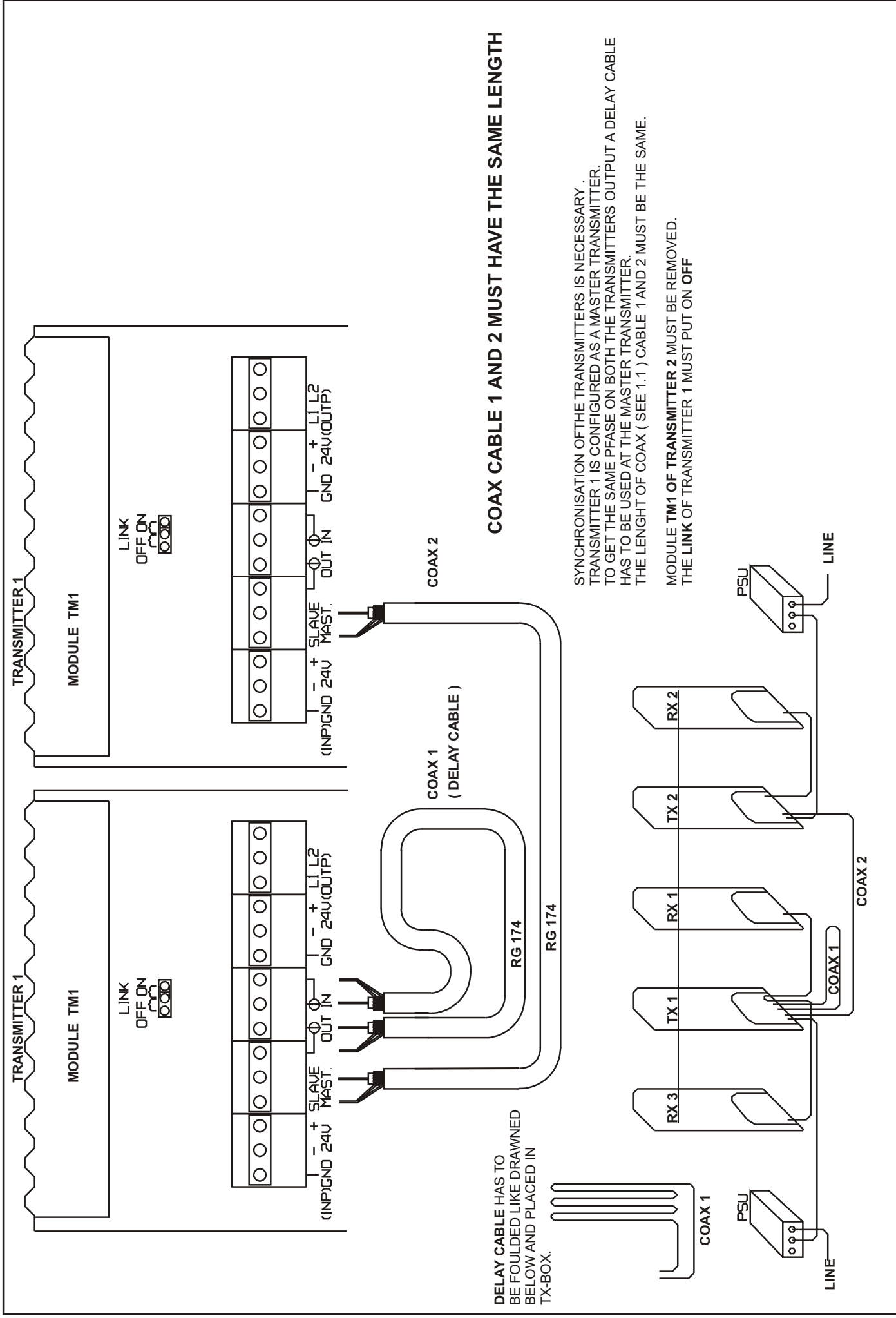

DELAY CABLE HAS TO BE FOULDED LIKE DRAWN IN BELOW AND PLACED IN TX-BOX.

COAX CABLE 1 AND 2 MUST HAVE THE SAME LENGTH

SYNCHRONISATION OF THE TRANSMITTERS IS NECESSARY . TRANSMITTER 1 IS CONFIGURED AS A MASTER TRANSMITTER. TO GET THE SAME PHASE ON BOTH THE TRANSMITTERS OUTPUT A DELAY CABLE HAS TO BE USED AT THE MASTER TRANSMITTER. THE LENGTH OF COAX (SEE 1.1) CABLE 1 AND 2 MUST BE THE SAME.

MODULE **TM1 OF TRANSMITTER 2** MUST BE REMOVED. THE **LINK** OF TRANSMITTER 1 MUST PUT ON **OFF**



6000 - SYSTEM

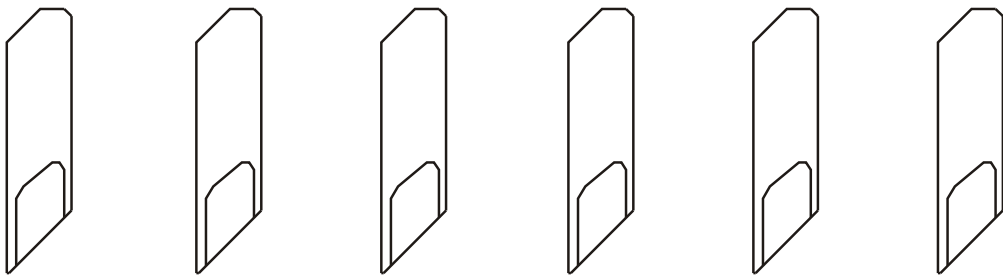

LP-CABLE = 4-WIRE CABLE (SEE 1.1)
 WIRE A = GND
 WIRE B = - 24V
 WIRE C = +24V
 WIRE D = NOT CONNECTED

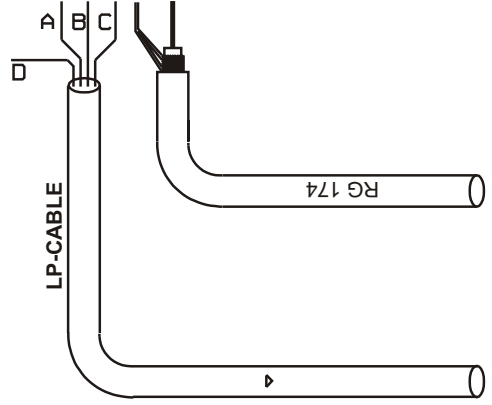

TO POWER SUPPLY

TRANSMITTER

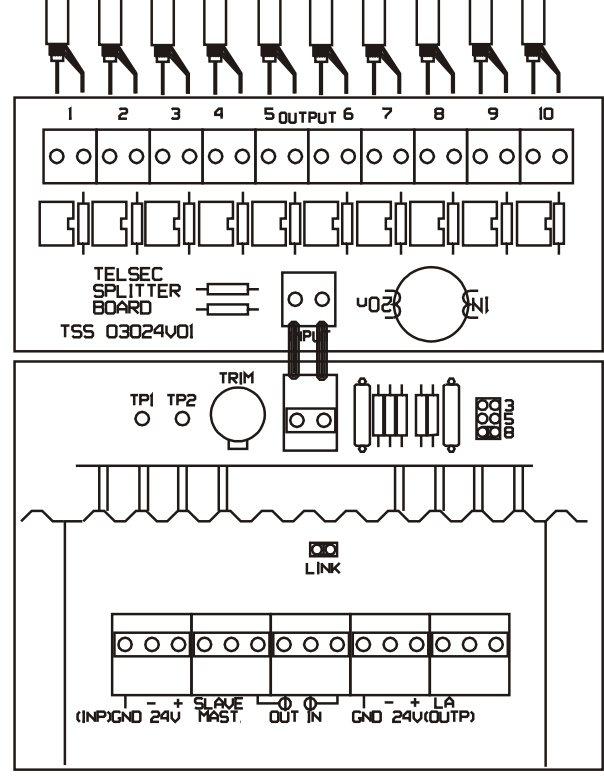

TO TRANSMITTERS
 OR STICKERDEACTIVATORS
 (IT IS NOT NECESSARY TO USE
 ALL OUTPUTS)

THE SYNCRONISATION UNIT IS BUILT IN A SEPERATE BOX
 IT NEEDS ITS OWN POWER SUPPLY FOR THE BEST RESULTS.

SYNCRONISATION INPUT WHEN THIS CSU MUST SYNCRONISED.
 IN THIS SITUATION TM 1 MUST BE REMOVED.

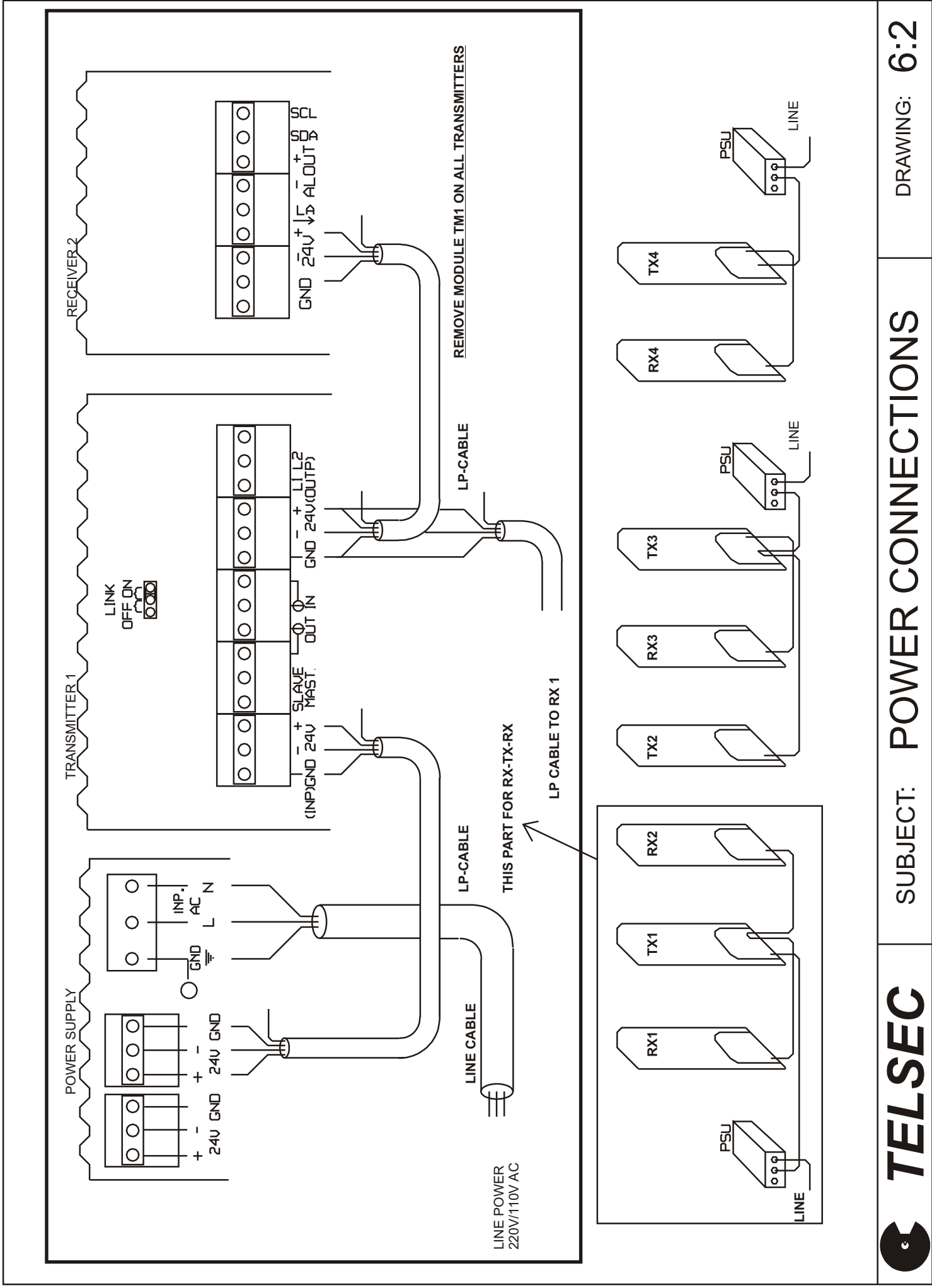

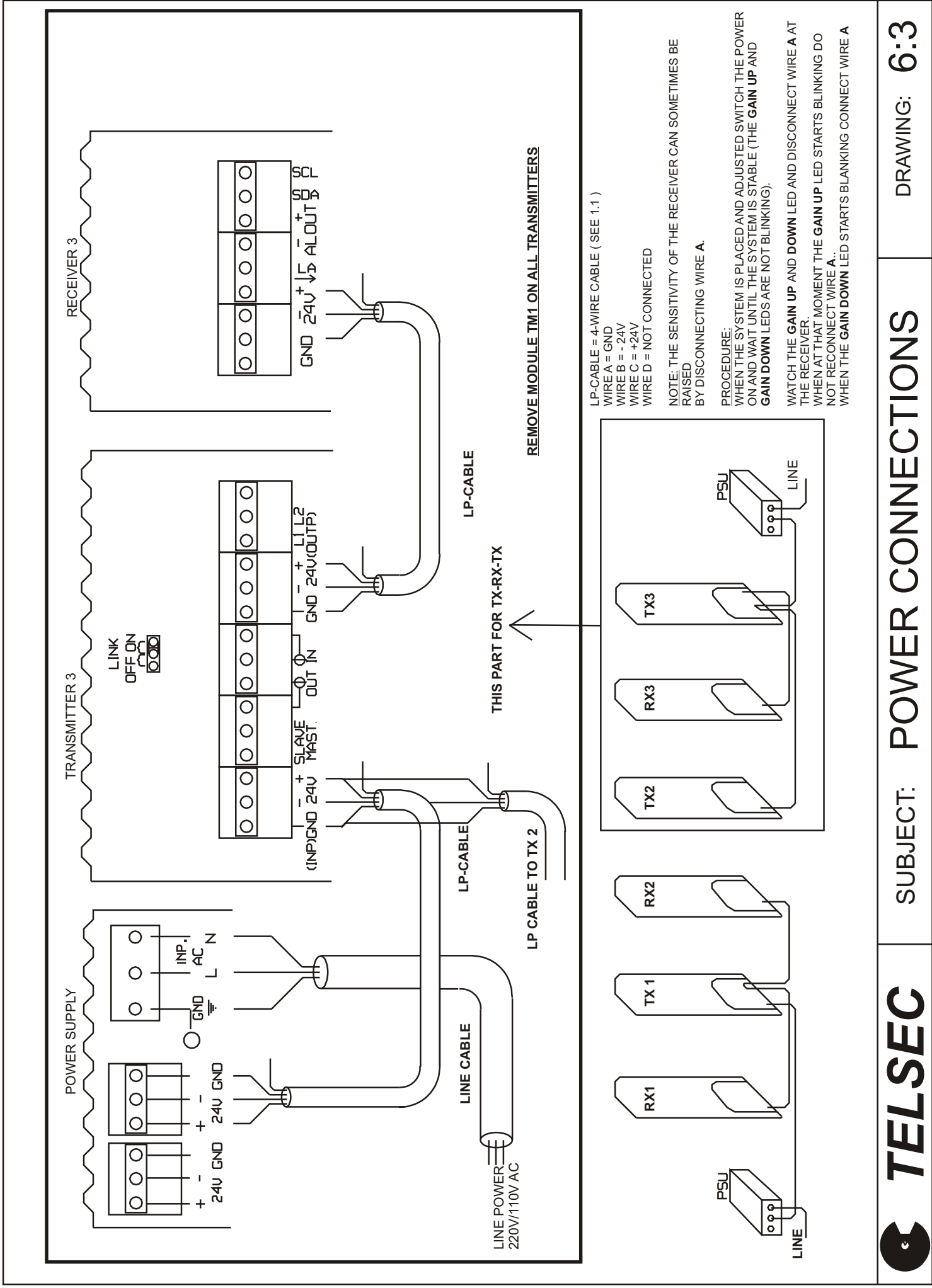

LP-CABLE = 4-WIRE CABLE (SEE 1.1)
 WIRE A = GND
 WIRE B = - 24V
 WIRE C = +24V
 WIRE D = NOT CONNECTED

NOTE: THE SENSITIVITY OF THE RECEIVER CAN SOMETIMES BE RAISED BY DISCONNECTING WIRE A.

PROCEDURE:
 WHEN THE SYSTEM IS PLACED AND ADJUSTED SWITCH THE POWER ON AND WAIT UNTIL THE SYSTEM IS STABLE (THE GAIN UP AND GAIN DOWN LEDS ARE NOT BLINKING).

WATCH THE GAIN UP AND DOWN LED AND DISCONNECT WIRE A AT THE RECEIVER.
 WHEN AT THAT MOMENT THE GAIN UP LED STARTS BLINKING DO NOT RECONNECT WIRE A.
 WHEN THE GAIN DOWN LED STARTS BLINKING CONNECT WIRE A

TRANSMITTER 1,2,3

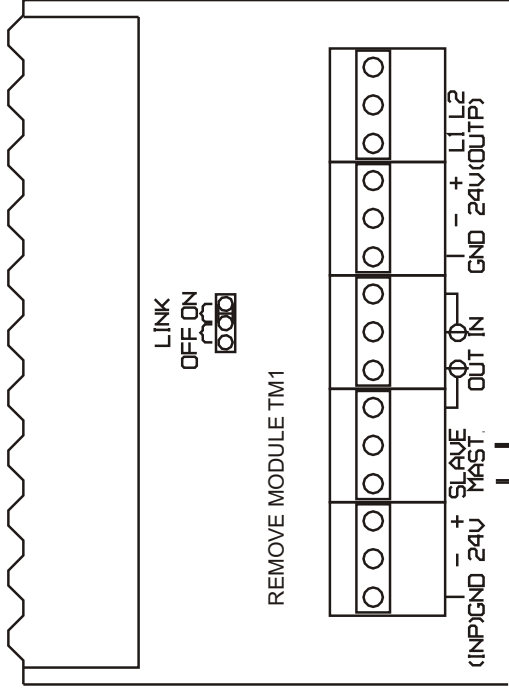

COAX CABLE WHICH IS TO LONG HAS TO BE FOULDED LIKE BELOW AND PLACED IN TX-BOX

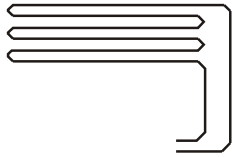

COAX 1 OR 2 OR 3.

RG174

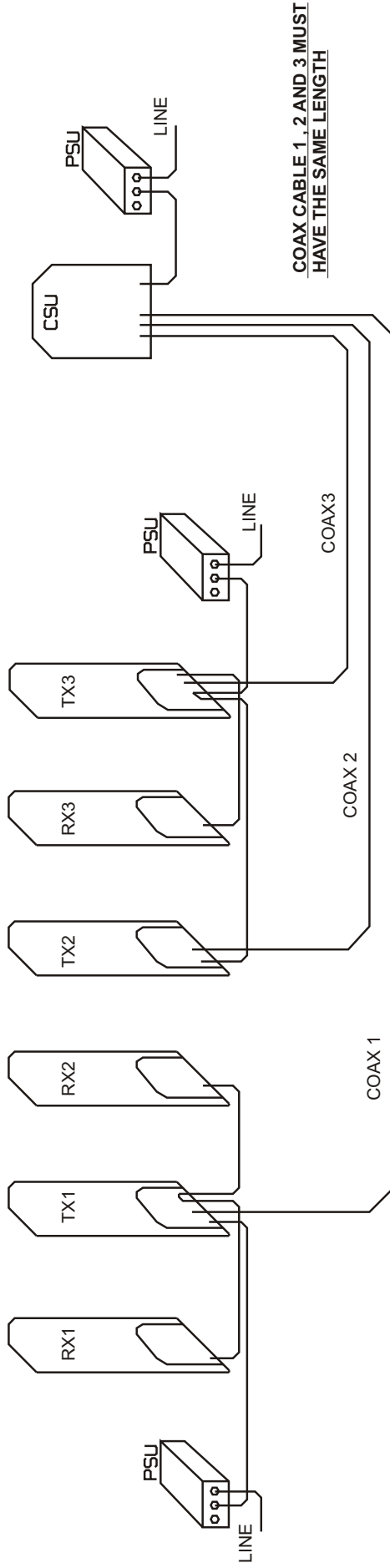

COAX CABLE 1, 2 AND 3 MUST HAVE THE SAME LENGTH



7000 - SYSTEM

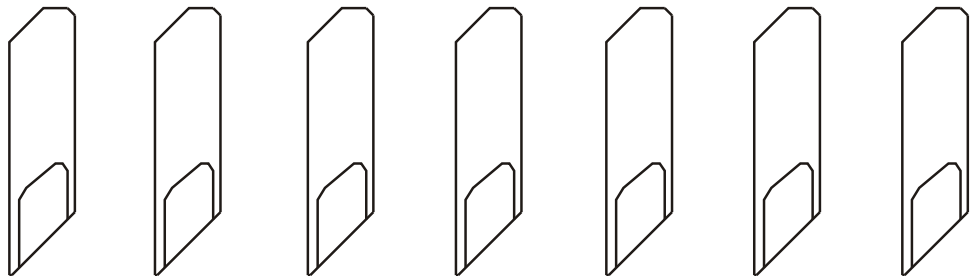

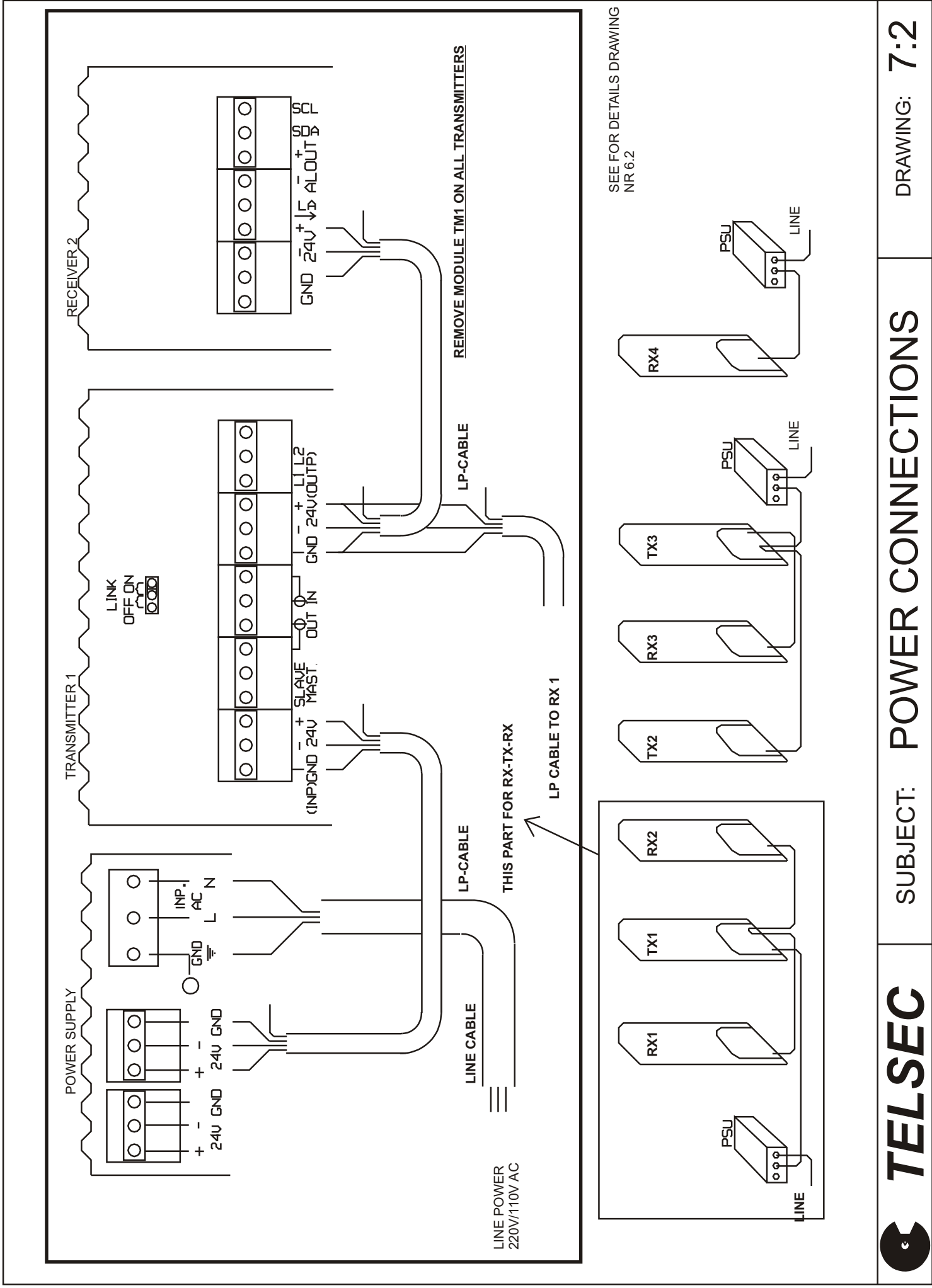



8000 - SYSTEM

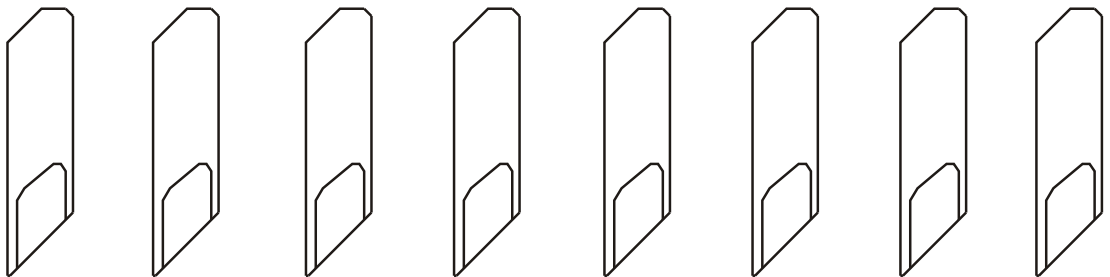

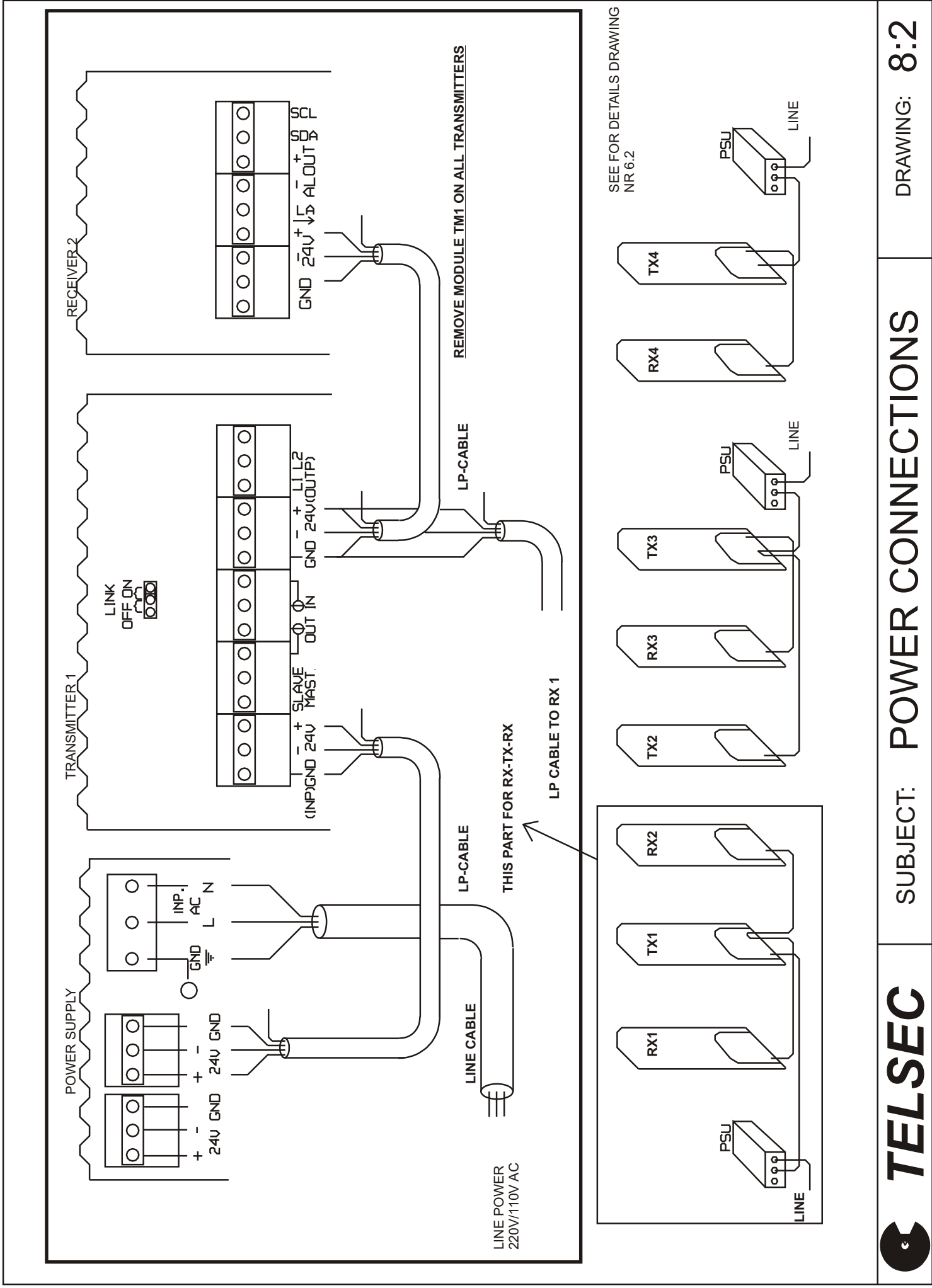

TRANSMITTER 1,2,3

LINK
OFF ON

REMOVE MODULE TM1

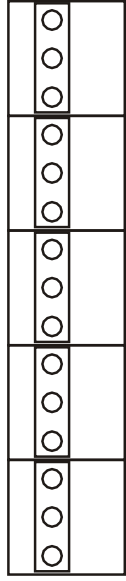

(IN) GND 24V SLAVE MAST OUT IN - + L1 L2 - + GND 24V (OUTP)



COAX 1 OR 2 OR 3.

RG174

COAX CABLE WHICH IS TO LONG HAS TO BE FOULDED LIKE BELOW AND PLACED IN TX-BOX

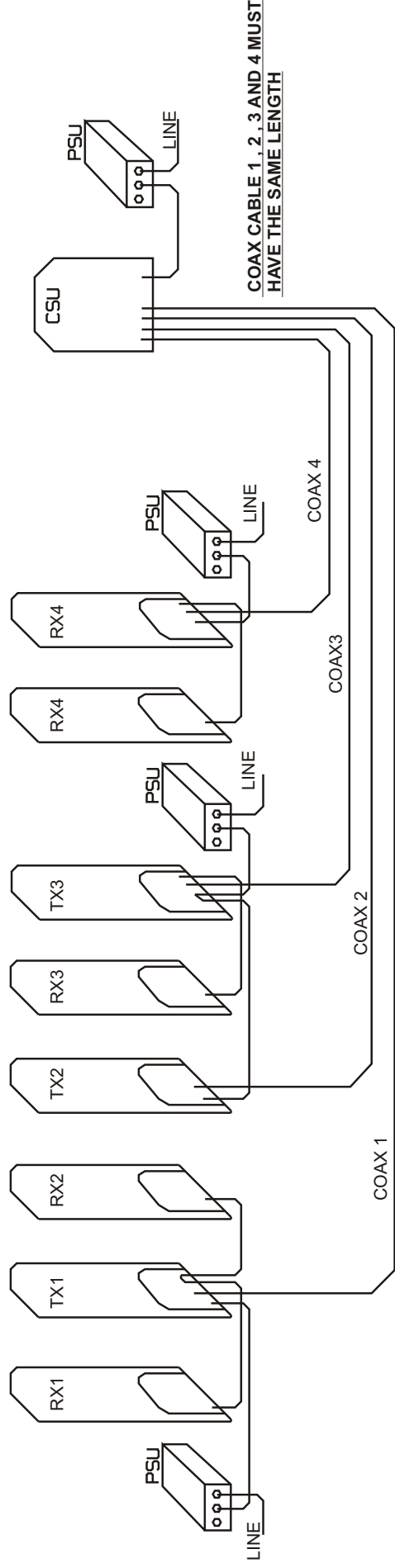
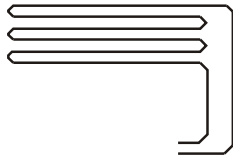

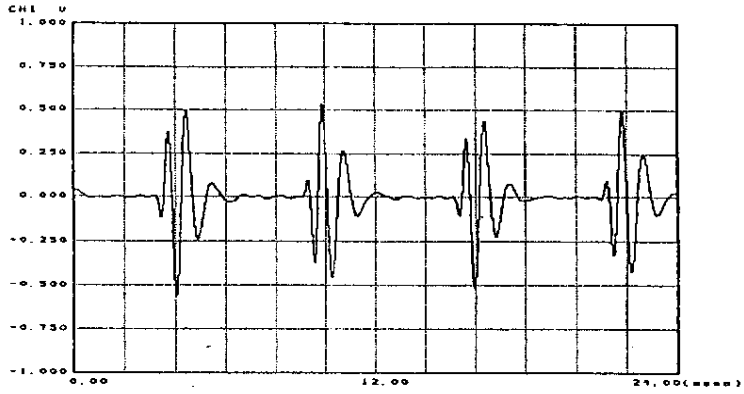

Fig.1 RX-TP5 with tag.

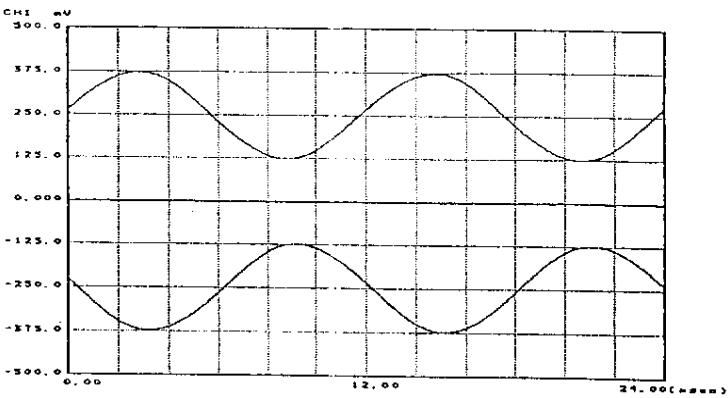

Fig.2 TX-Closed Loop (Not Correct)

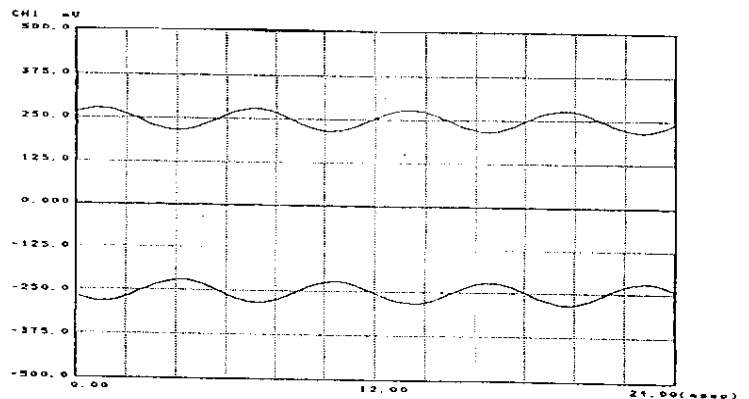

Fig.3 TX-Closed Loop (Correct)

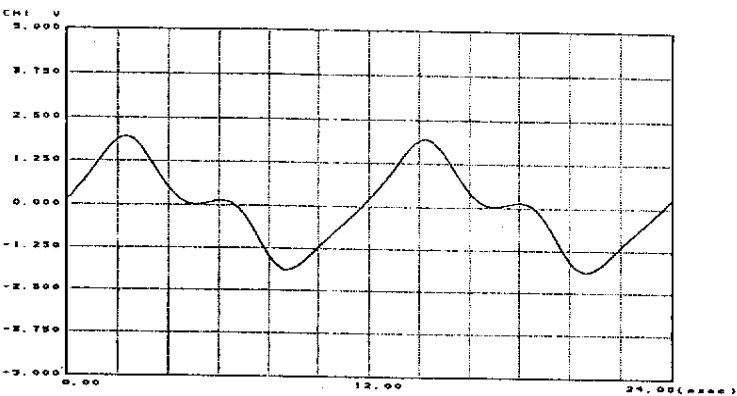

Fig.4 RX-TP3 (Not Correct)

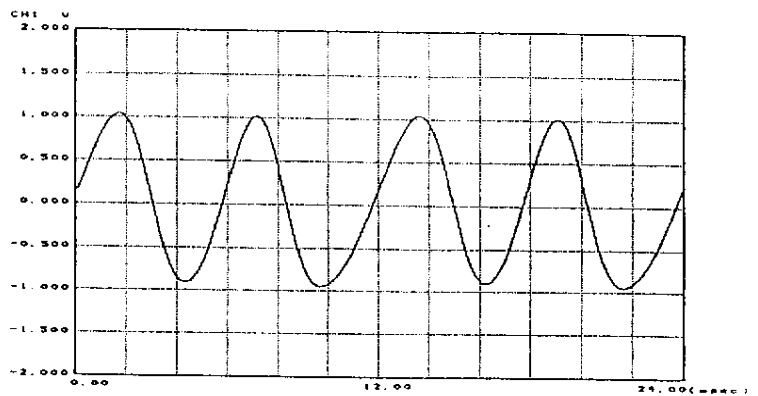

Fig.5 RX-TP3 (Correct)

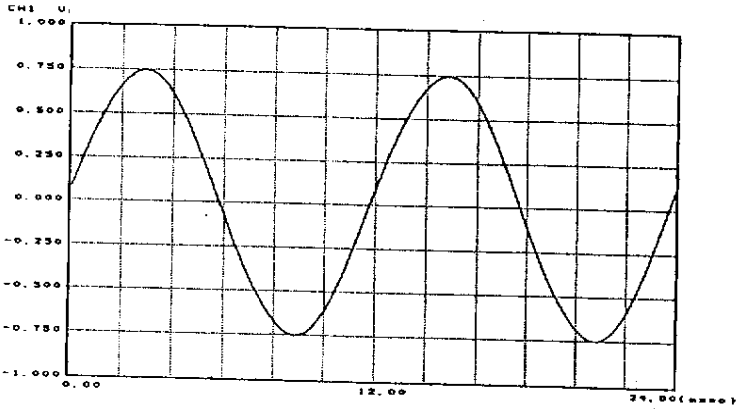

Fig.6 TX-TP3 Sweep-signal

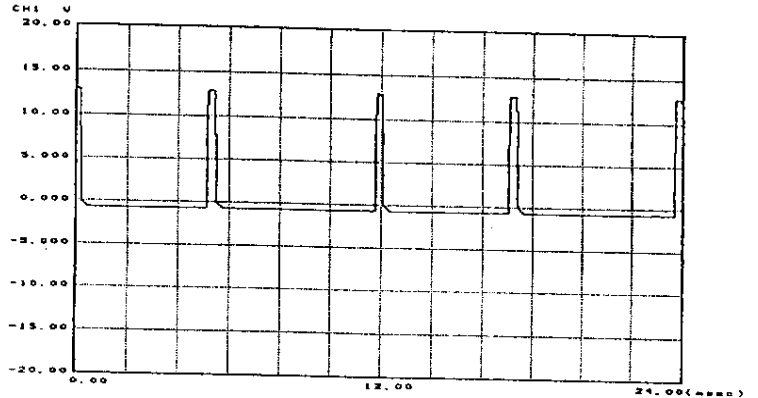

Fig.7 RX-TP7 Tag pulses